

KONE provides innovative and eco-efficient solutions for elevators, escalators, automatic building doors and the systems that integrate them with today's intelligent buildings.

We support our customers every step of the way; from design, manufacturing and installation to maintenance and modernization. KONE is a global leader in helping our customers manage the smooth flow of people and goods throughout their buildings.

Our commitment to customers is present in all KONE solutions. This makes us a reliable partner throughout the life cycle of the building. We challenge the conventional wisdom of the industry. We are fast, flexible, and we have a well-deserved reputation as a technology leader, with such innovations as KONE MonoSpace®, KONE NanoSpace™ and KONE UltraRope®.

KONE employs close to 50,000 dedicated experts to serve you globally and locally.

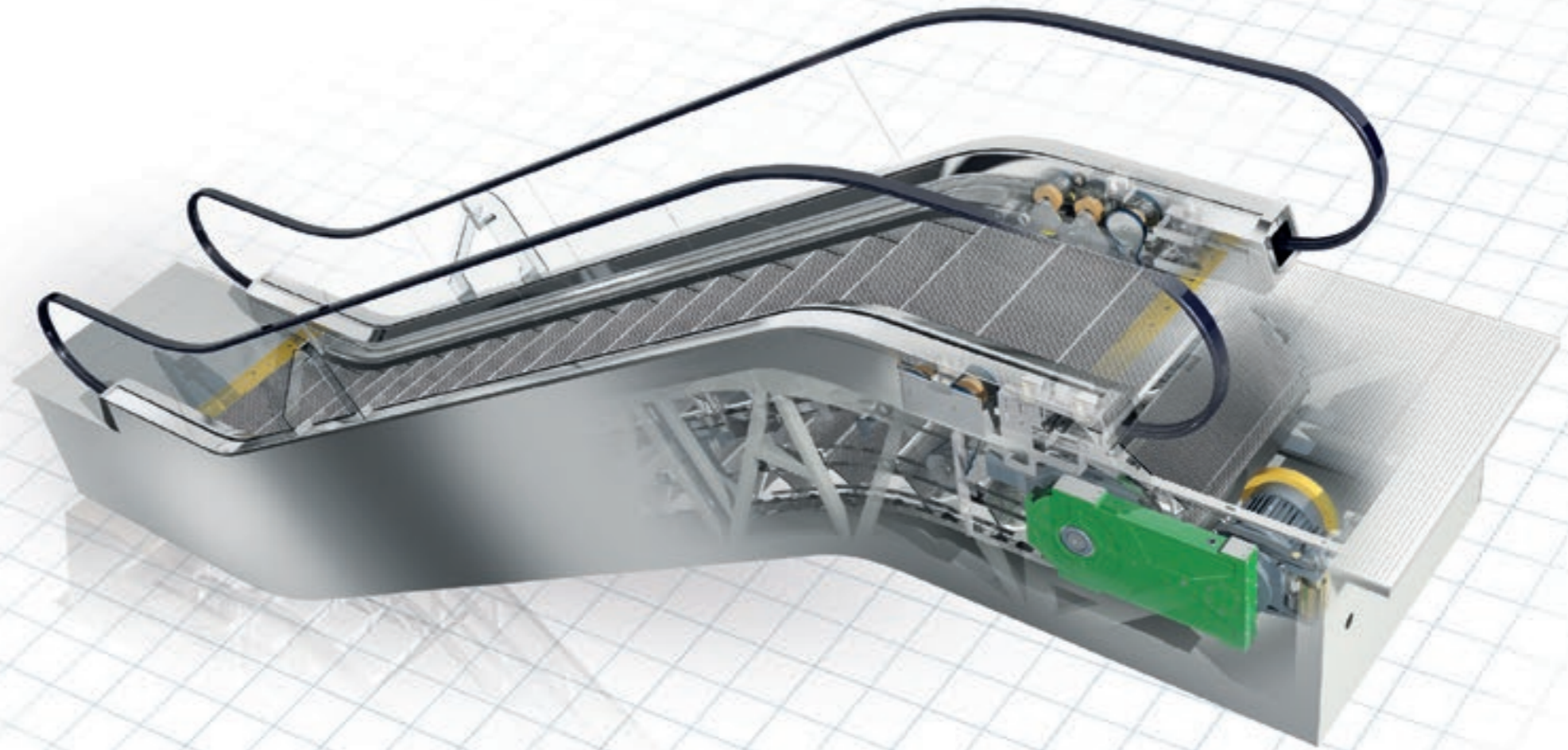

PLANNING GUIDE FOR

KONE Corporation
www.kone.com

This publication is for general informational purposes only and we reserve the right at any time to alter the product design and specifications. No statement this publication contains shall be construed as a warranty or condition, express or implied, as to any product, its fitness for any particular purpose, merchantability, quality or representation of the terms of any purchase agreement. Minor differences between printed and actual colors may exist. KONE MonoSpace®, KONE EcoDisc®, KONE Care® and People Flow® are registered trademarks of KONE Corporation. Copyright © 2016 KONE Corporation.



TABLE OF CONTENTS

1. Welcome to this Planning Guide	
2. How to use this Planning Guide	
Designing your new project.....	9
3. An introduction to escalators and autowalks	
3.1 Definitions and components.....	10
3.2 The main safety code to consider.....	12
4. Optimizing the PeopleFlow™ within the building	
4.1 Analyzing PeopleFlow™.....	15
4.2 Calculating traffic capacity.....	16
Case 1: Shopping center.....	19
Case 2: 24h metro station.....	21
4.3 Understanding your building segment.....	24
4.4 Deciding how many escalators and/or autowalks are needed.....	26
4.5 Locating your escalators and autowalks – indoors or outdoors?.....	29
4.6 Arranging your escalators or inclined autowalks in the building.....	32
5. Configuring your escalator or autowalk	
5.1 Load profile.....	40
5.2 Energy consumption.....	43
5.3 Step width.....	46
5.4 Nominal speed.....	48
5.5 Inclination of escalators.....	50
5.6 Inclination of autowalks.....	51
5.7 Horizontal (level) steps/pallets.....	52
5.8 Vertical rise (travel height).....	54
5.9 Transition radii.....	55
5.10 Operational modes.....	56
5.11 Type of balustrade.....	58
5.12 Balustrade height.....	60
6. Construction considerations	
6.1 Passenger circulation area.....	64
6.2 Minimum handrail and headroom clearance.....	65
6.3 Protective barriers.....	66
6.4 Head guards.....	68
6.5 Customer railings.....	69
7. Preparing the site	
7.1 The 6 Site Absolutes.....	74
7.2 Mounting locations.....	75
7.3 Intermediate truss support.....	76
7.4 Measurements prior to installation.....	77
7.5 Electrical requirements.....	78
7.6 Sprinkler system.....	78
7.7 Preparing to unload the escalator.....	79
7.8 Unloading the escalator.....	79
8. Installing the escalator or autowalk	
8.1 Installation in one complete section.....	84
8.2 Installation through the building in one complete section.....	85
8.3 Installation through the building in two or more sections due to site access restrictions.....	86
8.4 Site access headroom requirements.....	86
8.5 Lifting points and lifting frames.....	88
8.6 Protection of escalators and autowalks following installation.....	89
9. Escalator and autowalk delivery process	
10. Appendix	
10.1 What is changing with EN 115-1.....	94
10.2 Capacity.....	94
10.3 Equipment.....	94
10.4 Site Conditions.....	95
10.5 Use of trolleys and shopping carts.....	95

1. WELCOME TO THIS PLANNING GUIDE

Every minute of every day, somewhere in the world, millions of people are using escalators and autowalks. In department stores, shopping centers, cinemas, sports complexes, exhibition halls, airports, railway stations, metro stations and a host of other buildings, escalators and autowalks are quietly, efficiently, safely and unobtrusively transporting large numbers of people. The key to their smooth and successful operation is efficient planning.

Our objective is to deliver a performance edge to our customers by creating the best user experience with innovative People Flow™ solutions in the fast developing urban environment. This allows people to move around smoothly, safely and eco-efficiently in and between buildings.

For decades KONE has been providing industry-leading escalators and autowalks and we are one of the global leaders in the industry. This Planning Guide demonstrates our vast experience and expertise in this area. It is a clear, easy-to-understand and comprehensive guide to all the main process stages, from initial project planning to final commissioning.

It will help you select the correct solution for each specific application, and recommend ways to optimize the People Flow™ within your building. It will also help you understand the relevant building regulations and the European escalator and autowalk safety code.

In short, this Planning Guide will be your companion in each and every project you are involved with. I hope you find it helpful, and I wish you a successful escalator or autowalk project. Where you still have questions, please contact your local KONE sales representative, who will be delighted to give you the necessary support.

2. HOW TO USE THIS PLANNING GUIDE

There is no set method for using this Planning Guide. You can flick through the table of contents and quickly access the relevant information you need. The initial chapters deal with an introduction to escalators and autowalks and how to optimize people flow within your building. The guide then takes you through how to configure your solution and addresses key construction considerations. We also explain how to install the escalator or autowalk and look at some of the most pertinent changes to the EN 115-1 code.

At the end of the Planning Guide are lists of figures and tables. Again, these are added so you can quickly and easily access the figures and tables you need. For more product-specific information you may look at the accompanying product vs. segment matrix. This will allow you to see which KONE products we recommend for certain segments, such as public transportation, airport, retail, office, hotel, medical or leisure.

Based on our recommendations you can then look at the appropriate product-specific module to analyze the technical specifications of the product. You will immediately be able to see which product will best suit your particular project.

InfoPack™

The InfoPack™ is a memory stick that contains the complete Planning Guide in easy to read electronic format. This makes it easier for you to take the information with you to meetings, to project it on a screen, or to use as appropriate. The latest version of the Planning Guide can be downloaded directly from the InfoPack which is linked to KONE.com.

KONE.com

The Planning Guide can also be accessed from the KONE.com website.

Designing your new project

A Optimizing the People Flow – Defining how many units are needed

- Calculate traffic capacity (*Chapter 4*)
- Typical configurations per type of building (*Chapter 4*)
- Arranging the escalators or inclined autowalks (*Chapter 4*)

B Defining the right solution for your project

- Different characteristics of an escalator or autowalk (*Chapter 5*)
- Product recommendations per segment
- Product-specific modules including specifications, options and dimensions.

C Obtaining the dimensions

- Dimensions for installation (*Chapter 7 & 8*)
- Construction considerations in relation to safety code (*Chapter 6*)
- Escalator design tools found on InfoPack and www.kone.com

3. AN INTRODUCTION TO ESCALATORS AND AUTOWALKS

3.1 Definitions and components

An escalator is a moving staircase for transporting people between floors of a building. It is generally agreed that an escalator is the most efficient means to move large numbers of people between floors.

KONE's escalators come in a diverse range of specifications:

- **Inclination** 27.3° | 30° | 35°
- **Step width** 600 mm | 800 mm | 1000 mm
- **Speed** 0.5 m/s | 0.65 m/s | 0.75 m/s
- **Level steps** 2 | 3 | 4*
- **Environment** Indoor | semi-outdoor | fully outdoor

* only for infrastructure escalators

Item	Component
1	Handrail
2	Skirting
3	Steps/pallets
4	Decking
5	Balustrade
6	Horizontal steps/pallets
7	Drive station
8	Controller
9	Front plate
10	Handrail drive
11	Transition radii
12	Truss
13	Side cladding
14	Step chain
15	Tracks
16	Return station
17	Access cover plate
18	Newel

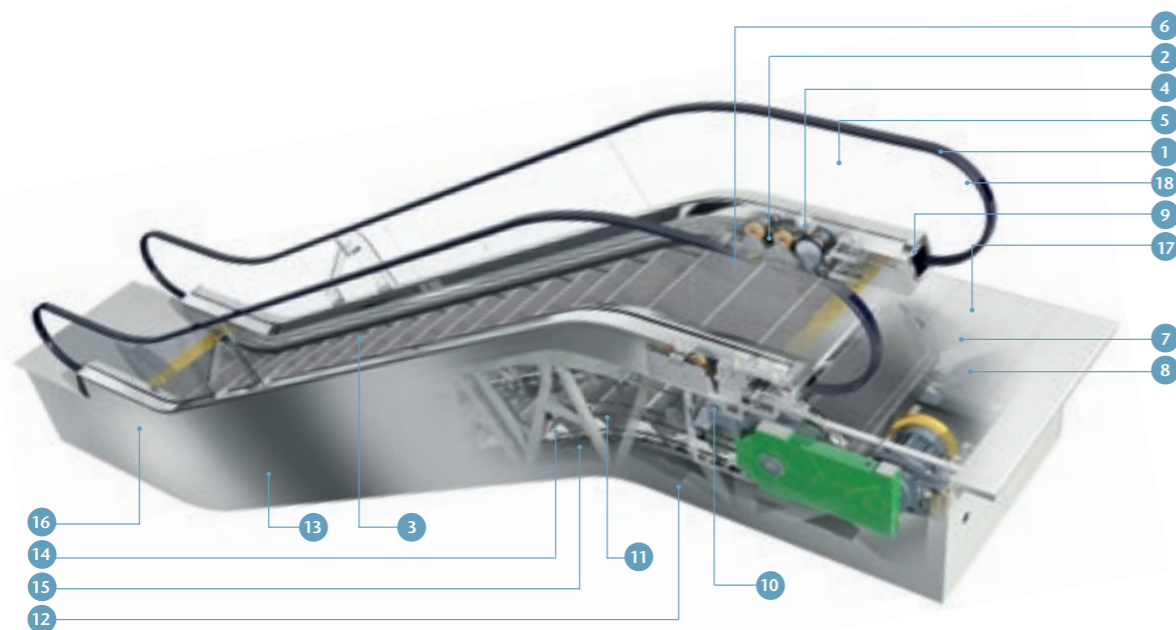

Figure 3.1 Escalator components

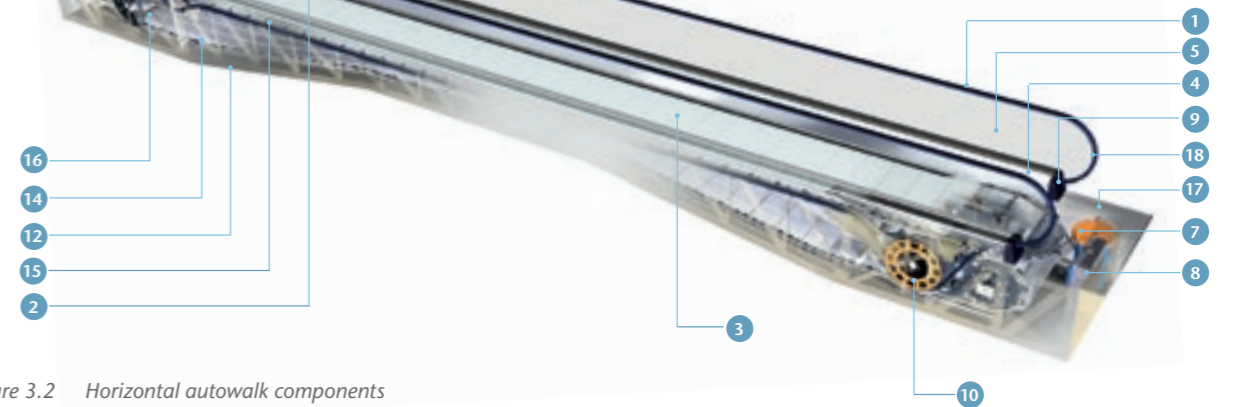

Figure 3.2 Horizontal autowalk components

A horizontal autowalk is a conveyor belt that transports people horizontally. Autowalks are generally provided in areas where people need to walk long distances with luggage, baggage carts or shopping trolleys. An autowalk is generally flat, but can be slightly inclined.

KONE's horizontal autowalks cover all the standard requirements:

- **Inclination** from 0° to 6°
- **Pallet width** 1000 mm | 1200 mm | 1400 mm
- **Speed** 0.5 m/s | 0.65 m/s | 0.75 m/s
- **Environment** Indoor | semi-outdoor | fully outdoor

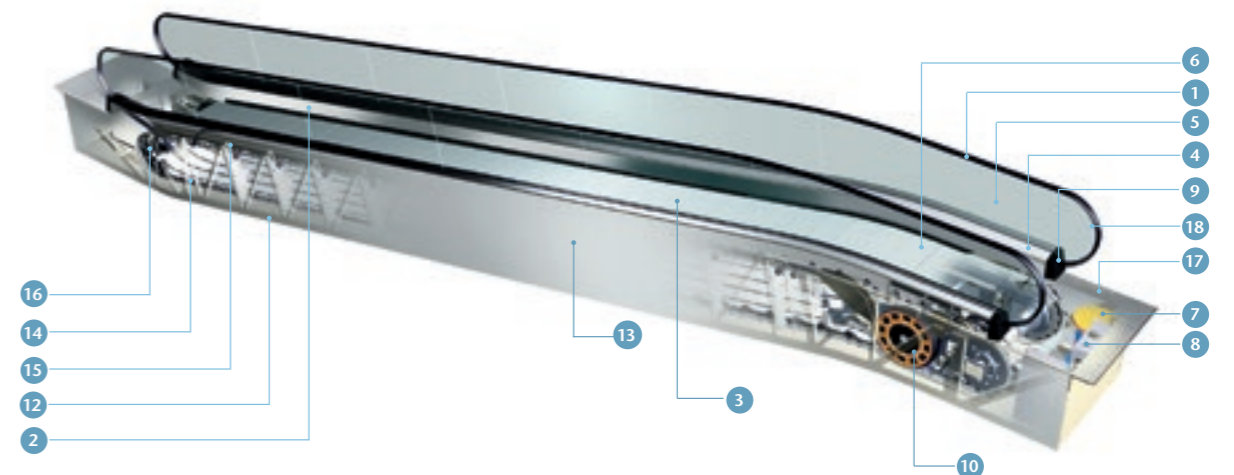

Figure 3.3 Inclined autowalk components

Inclined autowalks (also called ramps) are often used in retail environments such as hypermarkets, where they allow for the smooth transport of shopping trolleys.

KONE's inclined autowalks are available with three degrees of inclination:

- **Inclination** 10° | 11° | 12°
- **Pallet width** 800 mm | 1000 mm | 1100 mm
- **Speed** 0.5 m/s
- **Environment** Indoor | semi-outdoor

By conveying people continuously, escalators and autowalks ensure a smooth flow of people through a building. They have a high people transportation capacity, and in multi-level retail centers play a vital role in ensuring that all floors are visited evenly. Escalators and autowalks, along with elevators and automatic doors, are a total people and goods transportation solution. However, escalators, autowalks and elevators each have their own strengths, as shown in [Table 3.1](#), which will help you understand whether you need an escalator or an autowalk (or even an elevator).

Table 3.1 The main transportation characteristics of escalators, autowalks and elevators

Escalators	Horizontal autowalks	Inclined autowalks	Elevators
Continuous	Continuous	Continuous	Interrupted
Mass transport	Mass transport	Mass transport	Limited number
Short-medium distances	Medium-long distances	Short-medium	Higher rises
In between floors	On one floor	In between floors	In between floors
Steer people flow	Save time and effort	Steer people flow	Improve accessibility

3.2 The main safety code to consider

The safe structural design and installation of escalators and autowalks in buildings is defined and regulated in the European Union and other European countries* by the EN 115-1 standard.

Elsewhere in the world, regional or local country-specific codes as well as the EN 115-1 code may apply. Your local KONE sales organization will be delighted to provide you with details of your local regulations.

In this Planning Guide, we refer to the latest version (EN 115-1), which was rolled out to CEN member countries on 28 December 2008 replacing the former EN115:1995+A1:1998+A2:2004. See section 10 of this planning guide for more information about the changes in the latest version.

Where this Planning Guide refers to an EN 115-1-specific instruction or recommendation, the following icon is displayed:



* EN 115-1 is mandatory in Austria, Belgium, Bulgaria, Cyprus, Czech Republic, Denmark, Estonia, Finland, France, Germany, Greece, Hungary, Iceland, Ireland, Italy, Latvia, Lithuania, Luxembourg, Malta, Netherlands, Norway, Poland, Portugal, Romania, Slovakia, Slovenia, Spain, Sweden, Switzerland and United Kingdom.



National Grand Theatre,
Beijing, China
36 KONE escalators



Berlin Central Station
Berlin, Germany
54 KONE escalators

4. OPTIMIZING THE PEOPLE FLOW™ WITHIN THE BUILDING

4.1 Analyzing People Flow™

People flow varies immensely in each type of building. Understanding people flow will help you select the correct type and number of escalators and autowalks, and configure them correctly for the building.

The easiest way to understand people flow is to look at two buildings where the people flow is widely different: a multi-floor shopping center and a 24h metro station (see the case studies later in this chapter).

What is People Flow™?

By 2030 there will be two billion more people living in cities than there are now, making the urban population almost five billion. To support this influx of people into cities, the importance of building comfortable and efficient urban environments is paramount. At the same time, increased environmental awareness is demanding more eco-efficient and environmentally-friendly solutions. And let's not forget that an aging population requires more focus on better accessibility, safety and security.

KONE is dedicated to the development of sustainable urban living, and is committed to making urban environments better places for people to live in.

Our vision is to deliver the best People Flow™ experience. By People Flow we mean:

- Moving people smoothly, safely, comfortably and without waiting in and between buildings
- Ensuring high quality accessibility for everyone.

Furthermore, People Flow gives us direction for developing our offering to meet our customers' needs, and enables us to credibly sell, deliver and maintain complete solutions instead of just products.

4.2 Calculating traffic capacity

An important first step is to calculate the number of passengers you expect your escalator or inclined autowalk to transport.

EN 115-1 The EN 115-1 code indicates an average practical transport capacity rather than the previous theoretical approach. The figures are based on the step width and nominal speed of an escalator or inclined autowalk.

More detailed information on step width and speed can be found in chapters 5.3 and 5.4. Table 4.1 displays the information given within EN 115-1 for traffic flow planning purposes. However, these figures are only relevant if the escalator is running at full load, which only occurs during peak hours.

Table 4.1 Traffic capacity calculations according to EN 115-1

Step/pallet width	Nominal speed		
	0.5 m/s	0.65 m/s	0.75 m/s
600 mm	3,600 persons/h	4,400 persons/h	4,900 persons/h
800 mm	4,800 persons/h	5,900 persons/h	6,600 persons/h
1000 mm	6,000 persons/h	7,300 persons/h	8,200 persons/h

Example Consider a metro station escalator, with a speed of 0.65 m/s and a 1000 mm step width, in continuous operation in both directions for a period of 20 hours a day, 7 days a week and 365 days per year. If it was running at full load for the whole of its 20 hours of operation, its traffic capacity would be:

$$20 \text{ hours} \times 7,300 \text{ persons/hour} \\ = 146,000 \text{ persons per day}$$

In reality, during its 20 hours of operation per day, its passenger load will vary as follows:

- 40% full load (2,920 persons) for 3 hours = 8,760 persons
- 100% full load (7,300 persons) for 2 hours = 14,600 persons
- 50% full load (3,650 persons) for 8 hours = 29,200 persons
- 100% full load (7,300 persons) for 2 hours = 14,600 persons
- 40% full load (2,920 persons) for 5 hours = 14,600 persons

This makes a total of 81,760 persons carried over its 20 hours of daily operation at 61.2% equivalent load profile.

In case of shopping centers one should note that the use of shopping trolleys and baggage carts will reduce capacity by approximately 80%. Increasing the pallet width of horizontal autowalks beyond 1000 mm will not necessarily increase capacity as users need to hold the handrail. The additional width is principally to enable the use of shopping trolleys and baggage carts.

The conclusion therefore is that traffic capacity calculations are complicated as they are affected by a number of criteria. KONE experts are available to help you calculate the exact traffic capacity of your escalator or autowalk, to ensure it perfectly matches the requirements of the building.

When carrying out such traffic capacity calculations for your projects, please take into consideration that some other important factors come into play which may influence your traffic capacity:

- Every step is not likely to be 100% occupied
- In reality, many passengers leave at least one clear step between themselves and the passenger in front
- As the speed of the step band increases, step occupancy decreases, because passengers hesitate longer before boarding.



Kamppi shopping center
Helsinki, Finland
45 KONE escalators

Case 1: Shopping center

As seen in *Figure 4.1* the shopping center experiences three peaks:

- The first is at the beginning of the day and consists of employees and early shoppers, coffee shop visitors and people who cut through the center on their way to work
- The second is during lunch hour when people access the food court area (not on ground level) or stop at the shopping center during their lunch break
- The third is the time after work when most shoppers enter the center.

After the third peak the number of visitors quickly decreases until the center closes for the night. See *chapter 4.6* for more information on this subject.

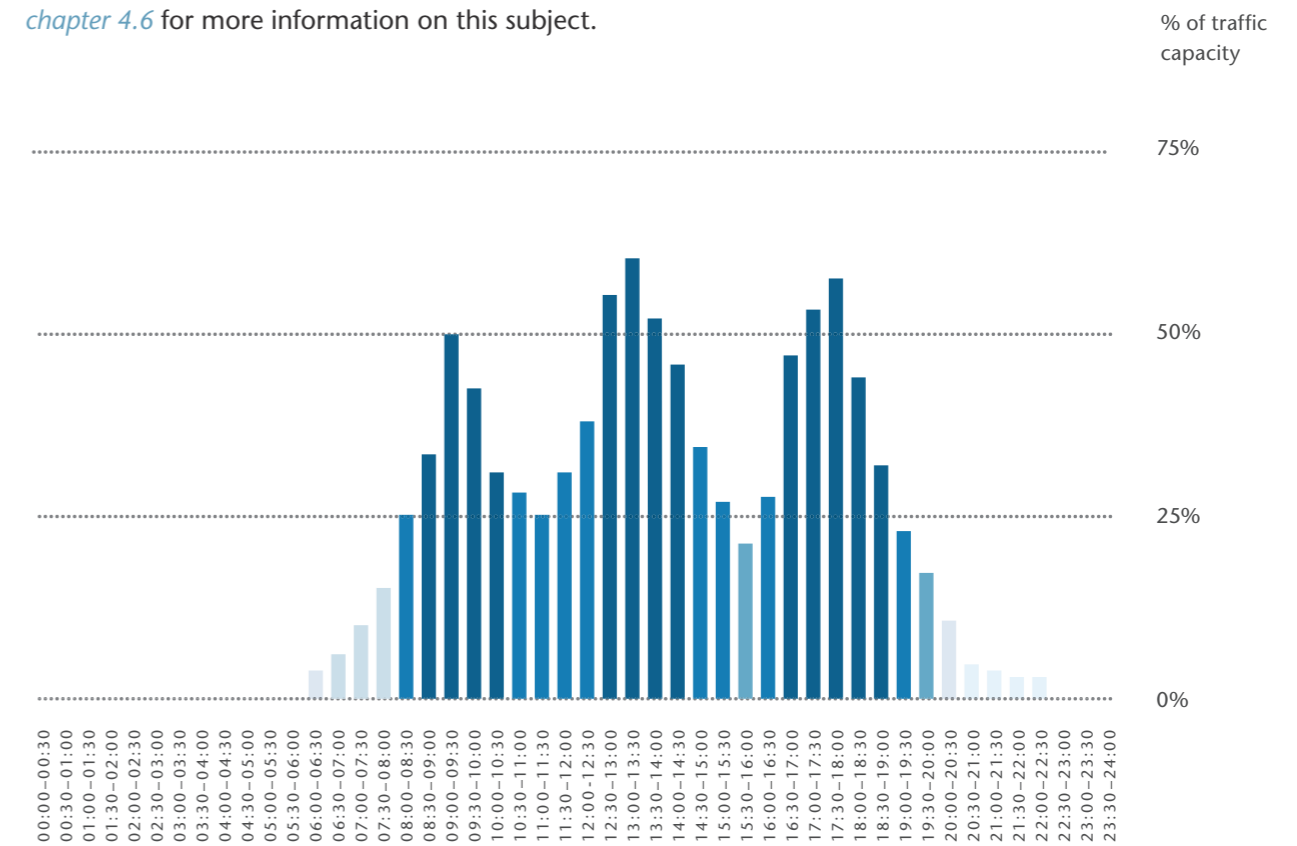

Figure 4.1 Typical people flow in a multi-level shopping center, showing three major peaks



Canary Wharf station
London underground
United Kingdom
20 KONE escalators

Case 2: 24h metro station

For a typical 24h metro station in a metropolitan city, two peaks are experienced; one for each rush hour when people travel to work and back, as shown in [Figure 4.2](#).

Both peaks are preceded and followed by a build-up period, which stretches longer into the evening as people either stay or travel for dinner, social meetings, overtime, etc.

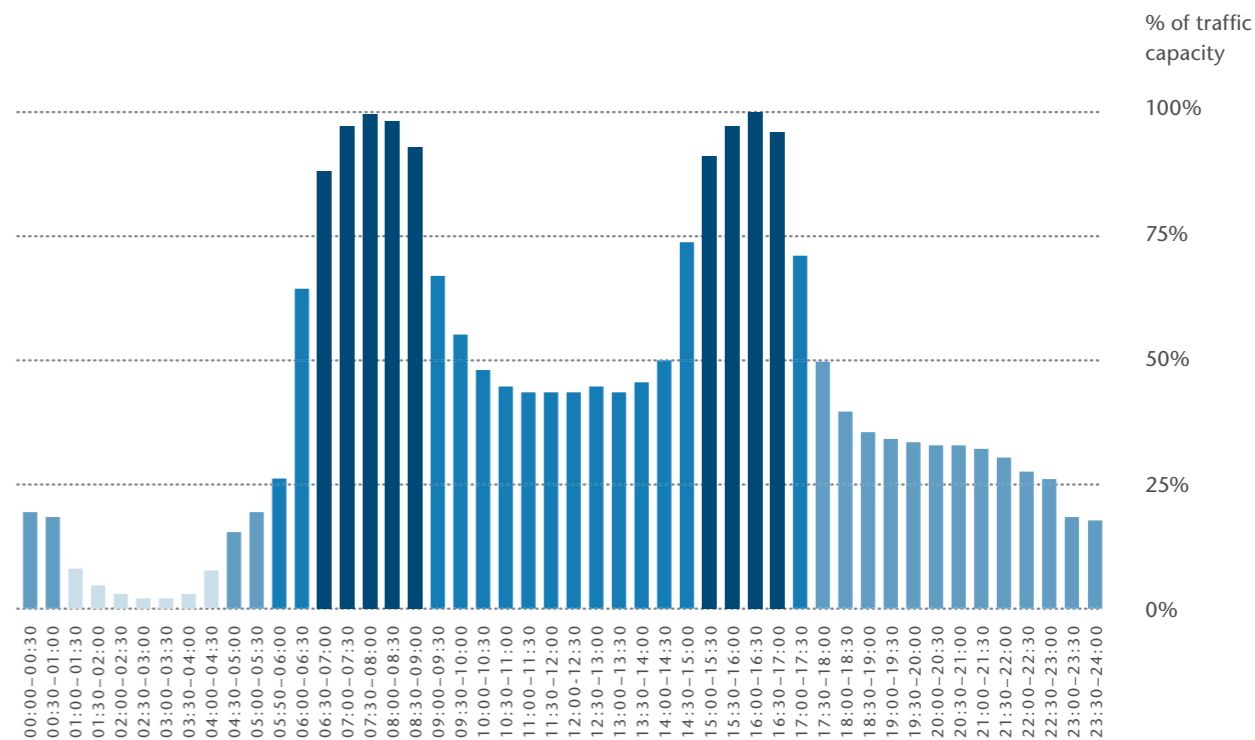

Figure 4.2 Typical people flow in a 24h metro station with two major peaks

Note that not only the number but the magnitude of the peaks are different between the two environments; in the metro station, the number of people using the escalator at peak times is significantly higher. This means that the escalator is under a much higher load. More on load profile is discussed in [chapter 5.1](#).

A clear distinction can be made between escalators for a commercial environment, such as a shopping center, and escalators for an infrastructure environment, such as a railway or metro station:

Commercial escalators and inclined autowalks



In shopping centers, supermarkets and department stores, escalators and inclined autowalks play a vital role in routing shoppers to the right location, such as particular shops in a mall or specific aisles in a store.

The specific KONE solutions that are recommended for each segment can be found in the [product vs. segment matrix](#). [Table 4.2](#) presents some typical configurations for commercial units, while [Table 4.3](#) highlights typical configurations for infrastructure units.

Infrastructure escalators and horizontal autowalks

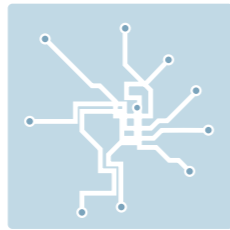

In public transportation environments such as airports and transit centers, the challenge is to get passengers and their luggage to their destination on time. To meet this challenge, escalators and horizontal and inclined autowalks are being increasingly used in these buildings.

Table 4.2 Typical configurations for commercial units

Small retail shops	Hypermarkets	Large shopping malls
35° escalator	12° inclined autowalk	30° escalator
800 mm step width	1000 mm pallet width	1000 mm step width
0.5 m/s	0.5 m/s	0.5 m/s
Stand-by speed or Stop & Go operation ¹	Continuous	Continuous
Glass balustrade	Glass balustrade	Glass balustrade
Primed sheet steel side cladding	Primed sheet steel side cladding	Customized or stainless steel side cladding

Table 4.3 Typical configurations for infrastructure units

Railway station	Metro station	Airport	Airport
30° escalator	27.3°/ 30° escalator	30° escalator	0° horizontal autowalk
1000 mm step width	1000 mm step width	1000 mm step width	1000 mm pallet width
0.65 m/s	0.65 m/s	0.5 m/s	0.65 m/s
Continuous, stand-by and Stop & Go operation ¹	Continuous, stand-by and Stop & Go operation ¹	Stop & Go operation	Stop & Go operation
Glass or solid inclined balustrade	Glass or solid inclined balustrade	Glass balustrade	Glass balustrade
Stainless steel side cladding	Stainless steel side cladding	Customized or stainless steel side cladding	No cladding

¹ See chapter 5.10 for the description of operational modes.

4.3 Understanding your building segment

Not all buildings can be described as either commercial or infrastructure; there are many building segments, each with their own people transportation requirements. Before choosing an escalator or autowalk, it is important to be aware of the key differences between major types of building, as their use and their people flow affect the solution you will specify. KONE is fully aware of these differing requirements and offers complete equipment and service solutions for any people flow challenge. Please contact KONE for any people flow planning support you may require. The main segments and their most common people transportation requirements are shown below:

Public transportation segment



- High availability is vital
- High speed (mainly 0.65 m/s) increases safety by allowing passengers to leave the platform quickly
- Linked to building management systems
- Stand-by speed and Stop & Go operation
- Heavy indoor, semi-outdoor and fully outdoor use
- 20-24 hrs running time per day.

Airport segment



- High speed is usually required, especially for horizontal autowalks
- Visual design is very important; airports are key reference sites
- Availability is extremely important
- Linked to building management systems
- Stop & Go operation
- Mainly indoor
- 18-20 hrs running time per day.

Retail segment



- Visual design and lighting options important
- Very often belongs to the transport system of the building and linked to elevators
- Lowest possible speed to retain shoppers in the building
- Continuous operation very important to guide shoppers to other floors
- Mainly indoor
- 12-14 hrs running time per day.

Office/hotel/medical segment



- Visual quality outlook important as it represents the luxury level of the building
- Finishing often done by customer (office/hotel)
- Very often belongs to the transport system of the building and is linked to elevators
- Low running speed needed for passenger comfort
- Stand-by speed and Stop & Go operational modes
- Mainly indoor and air-conditioned
- 10-12 hrs running time per day.

Leisure segment



- Availability is extremely important
- Amusement parks often have busy retail center type of traffic but in an outdoor environment
- Stadiums where the duty cycle is short but with peak loads require a heavier solution, similar to the public transportation segment
- Indoor, semi-outdoor and fully outdoor use
- 12-14 hrs running time per day.

4.4 Deciding how many escalators and/or autowalks are needed

The number of units required is determined by the people flow requirements (the number of people transported per hour). This depends on parameters such as:

- The type of building
- The traffic flow within the building
- Peak traffic times
- The level of travel comfort required.

In addition, factors such as safety, evacuation, accessibility and even the marketing potential (of a retail center) come into play. The next consideration is where to locate your escalators and autowalks.



Bishan Station
Singapore
16 KONE escalators



Sello shopping center
Espoo, Finland
20 escalators
12 autowalks

4.5 Locating your escalators and autowalks – indoors or outdoors?

To ensure the reliability and availability of your escalators and autowalks over their lifetime, it is essential that their specifications match the environmental conditions.

Most escalators and autowalks will normally be installed indoors. They are designed for such an environment as standard. An indoor environment is defined as a weather-tight, temperature controlled environment where the escalator or autowalk will not be exposed to the elements such as rain and snow.

An outdoor environment can be either semi-outdoor or fully outdoor

Semi-outdoor is an uncontrolled environment in which the unit might be exposed at times to the elements. However, as it is covered with a roof and walls, the escalator is not directly exposed to the elements.

Fully outdoor is an uncontrolled environment where the unit will be fully exposed to the elements. A key consideration is therefore the temperature; heaters and/or coolers may have to be installed, depending on the climate.

Example The average energy consumption of heaters are the following:

- 4.5 m high rise escalator = 3,900 kWh/year
- 8.0 m high rise escalator = 5,700 kWh/year

The above figures are based on a 4 month winter period and operating for 20 hours/day, 7 days/week and 52 weeks/year.

EN 115-1 EN 115-1 recommends that outdoor escalators are covered by a roof. This is for safety reasons.

For example, passengers on a fully outdoor escalator when it is raining are likely to hold umbrellas as well as shopping trolleys/bags and therefore not the handrail, which could be dangerous.



Figure 4.3 The outdoor escalator should be covered by a roof to improve passenger safety and convenience.



Sala Daeng station
Bangkok, Thailand

The operational environment does not restrict the use of KONE escalators and autowalks. If they are to be installed in a semi-outdoor or a fully outdoor environment, numerous features are available to upgrade the specification of the unit to suit the environment and ensure lifetime performance. These features are listed in [Table 4.4](#) and [Table 4.5](#).

Table 4.4 Recommended specifications for a semi-outdoor escalator

Application	This specification is for escalators installed in an uncontrolled environment, but which are covered with a roof and walls, thereby preventing them from being directly exposed to rain, water and snow etc.
Recommended options	<ul style="list-style-type: none"> • Truss with bicomponent epoxy zinc dust anti-corrosion paint and synthetic resin finishing coat • Water drain and oil collection channels in truss • Stainless steel skirts with clear anti-friction coating • Automatic step chain lubrication, not required with lubrication-free chains • Weatherproof electrical system • IP55 motor • Step chain covers • Stainless steel handrail guide • Step & step chain rollers with sealed bearings • IP54 exposed electrical components.
Remarks	In hot (>40°C) or cold (<4°C) climates, appropriate cooling or heating options need to be selected

Table 4.5 Recommended specifications for a fully outdoor escalator

Application	This specification is for an escalator installed in a fully outdoor environment, and as such will be exposed to rain, water and snow etc.
Recommended options	<ul style="list-style-type: none"> • Hot-dipped galvanized truss with non-decorative galvanized sheet steel truss side panels, including corrosion protection for all necessary steel components • Stainless steel handrail guide • Stainless steel skirts with clear anti-friction coating • Automatic step chain lubrication, not required with lubrication-free step chains • Step chain covers to prevent rainwater penetrating the step connector (stub axle) brushes • Step rollers with sealed bearings • Optional lubrication-free step chain with sealed chain roller bearings • Water drain and oil collection channels in truss with oil/water separator, to prevent step chain oil polluting the drainage system The pit must be 200 mm deeper to accommodate this feature • Water level safety switch in lower machine compartment to stop the escalator in the event of the pit flooding with rainwater • Weatherproof electrical system • All exposed electrical components IP54 rated
Remarks	In hot (>40°C) or cold (<4°C) climates, appropriate cooling or heating options need to be selected

The product-specific modules in this Planning Guide contain information about which escalators and autowalks have the possibility to be installed in uncontrolled environments.

4.6 Arranging your escalators or inclined autowalks in the building

Escalators are generally acknowledged as being the most effective method of transporting large numbers of people between two floor levels, but how your escalators are arranged within the building has a huge impact on the flow of people. More specific information on this topic and how it relates to construction considerations is provided in [chapter 5](#).

In infrastructure buildings

- Escalators are normally positioned on the main routes through the building
- The over-riding requirement is speed and efficiency of people transportation within a safe environment.

In retail stores

- Positioning an escalator next to the main entrance is the most effective way to encourage customers to use a sales area on another floor level
- In a retail environment the goal is not merely to convey passengers to another floor as quickly as possible. An escalator can lead people through a promotional area or alongside displays of goods.

Note that the actual arrangement of the escalator installation can have a dramatic impact on the interior design of the building. The most common escalator arrangements are shown on the following pages, along with advantages and disadvantages of each configuration. KONE escalators are designed to be operated in both directions, so at this stage you do not necessarily have to stipulate the direction of travel.



Suvarnabhumi Airport
Bangkok, Thailand
24 KONE autowalks

A single escalator arrangement, free standing or against the wall

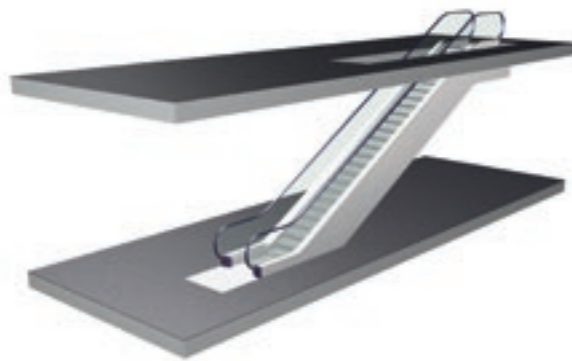

- + An inexpensive method of transporting passengers between two floor levels
- + Particularly suitable for small retail stores where available floor space is restricted
- + Only one side of decorative truss side cladding is required if against the wall
- Only really suitable for installations where passenger flow is in one direction, although on-demand starting can be utilized to allow travel in both directions
- An easily accessible staircase is required for passengers to return to the ground floor level
- Restricts traffic flow within the building

Multi-level scissor arrangement (continuous traffic flow)

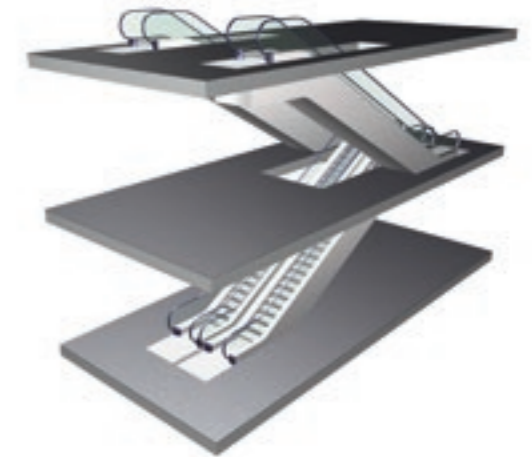

- + Cost-effective and efficient method for transporting passengers between three floor levels
- + Continuous arrangement allows the fastest movement of passengers over two or more floor levels, so is particularly suitable for public service buildings, office buildings or large department stores

With a single multi-level scissor escalator arrangement:

- Only really suitable for installations where passenger flow is in one direction
- Readily accessible staircases are required for passengers to return to the ground floor level

Escalators in parallel arrangement

- + Passenger flow within the building is maximized by moving the users between the two floors
- + Increased passenger comfort in comparison to single arrangement
- + Both sides can be used for promotional purposes

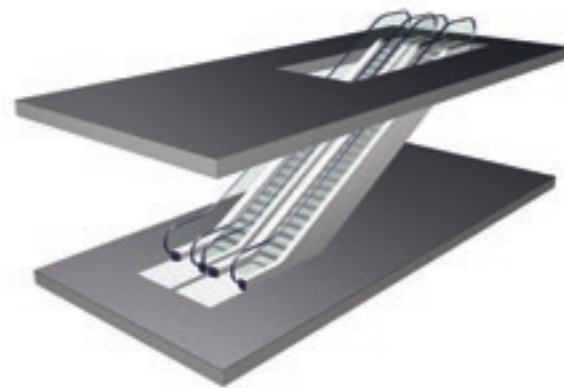

Multi-level criss-cross arrangement (continuous traffic flow)

- + Continuous arrangement allows the fastest movement of passengers over two or more floor levels, so is particularly suitable for public service buildings, office buildings or large department stores
- + Reduces congestion at the landing areas by separating upwards and downwards traveling passengers
- + Frequently used to make an attractive feature of the escalators in the center of retail stores

Escalators in one travel direction (interrupted traffic flow)

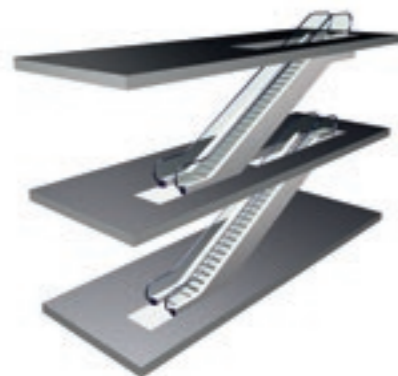

- + Cost-effective method for transporting passengers between three floors
- + In retail installations, passengers have to make a short detour to the next escalator; strategically placed displays alongside the route of this detour can help to increase sales by encouraging impulse buying
- Only really suitable for installations where passenger flow is in one direction
- Passenger flow through the building is interrupted, so overall traveling time to higher floor levels is increased
- Readily accessible staircases are required for passengers to return to the ground floor level

Multi-level parallel arrangement (interrupted traffic)

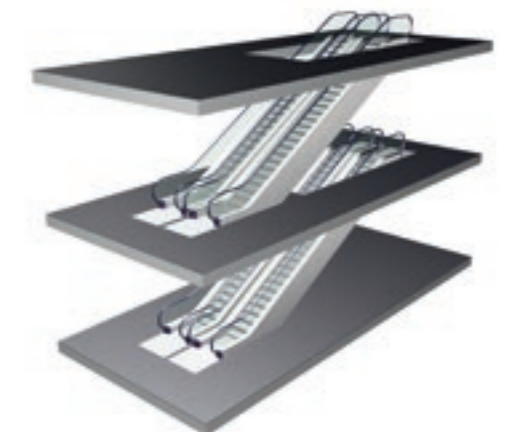

- + In retail installations, passengers have to make a short detour to the next escalator; strategically placed displays alongside the route of this detour can help to increase sales by encouraging impulse buying
- + The possibility to reverse the direction of travel of both escalators depending on the usage or traffic flow
- Passenger flow through the building is interrupted, so overall traveling time to higher floor levels is increased

If you need traffic planning data or recommendations on how to improve the people flow within a particular building, please contact your local KONE sales organization.

SUMMARY

Having decided on the number, location and arrangement of the escalators and autowalks needed to provide the most efficient traffic flow in the building, you can now turn your attention to the detailed specifications of the selected equipment, which is the subject of the next chapter.

Suvarnabhumi Airport
Bangkok, Thailand
24 KONE autowalks

5. CONFIGURING YOUR ESCALATOR OR AUTOWALK

Each escalator or autowalk is a complex combination of components and technical characteristics. Many of these characteristics – such as speed, step width, inclination, vertical rise etc. – are available in various specifications. To make the selection of equipment as straightforward as possible, we have standardized many of these characteristics in our ranges of commercial escalators and inclined autowalks. However, our infrastructure units are less easy to standardize due to a more diverse spectrum of requirements.

The purpose of this chapter is to walk you through these various possibilities and make recommendations for each type of building. Our goal is to ensure that your escalators and autowalks are properly configured to optimize the required flow of people through the building.

In addition, we also bring your attention to the key code related restrictions of EN 115-1, where applicable. This will help you make the best informed decisions for the configuration of your units in your particular region or country.

*Debenhams department store
Liverpool, United Kingdom
10 KONE escalators*

5.1 Load profile

In [chapter 4.2](#) (metro station) we briefly mentioned the load profile. This is the indication of the passenger flow in a building and how the escalators and autowalks are stressed. A load profile is based on the quantity of passengers traveling on an escalator or autowalk, and the length of time and frequency they spend riding it. As we have seen, a load profile for a commercial escalator in a retail center is going to be different from that of an infrastructure escalator in a city metro station.

The following factors have an influence on the load profile:

Maximum step load

This is the maximum load on a particular step at any time. It is based on average weights of passengers and takes into consideration:

- Not every step is occupied all the time
- Only the visible steps can be loaded
- The step width, which influences the number of passengers.

Average level of use

The level of use of an escalator varies throughout the day. In most public transportation settings, peaks occur during rush hours, but for most of the day there is less traffic. Each load profile has an average percentage based on the height and frequency of these peaks, troughs and plateaus.

Minimum safety factor

Different key components have different set tolerances, which exceed the load by a set factor. In other words, they are stronger or more durable. This is indicated by the safety factor (SF).

Truss

When the length of the escalator/inclined autowalk results in the truss exceeding the maximum permitted deflection between the supports required by the local safety codes and specification requirements etc., you should provide an intermediate truss support (see [chapter 7.3](#)). Please contact your local sales organization for more details.

Step chain

Two designs for step chains are available. They differ as to whether the step chain rollers are inside or outside the step chain. The most commonly used step chains have inside rollers, and are used mainly for low to mid traffic applications. Outside rollers are usually used for mid to high traffic situations. Both designs fulfill the EN 115-1 safety factor 5 as a minimum.

A way to increase the availability of your escalator is to locate the step chain rollers outside the chain links (available in KONE infrastructure escalators), as it leads to multiple benefits:

- It spreads the passenger load over a greater area, thus reducing wear in the step chain pins and bushes; this is essential in demanding infrastructure environments
- Large diameter (100 mm) step chain rollers rotate at a slower speed than smaller diameter (75 mm) rollers, resulting in a longer tire life
- Damaged or worn rollers can be quickly replaced without splitting the step chains, thereby maximizing availability by minimizing downtime
- The drive and tension carriage sprockets mesh with the step chain, not the step chain roller. This extends the tire and bearing life.

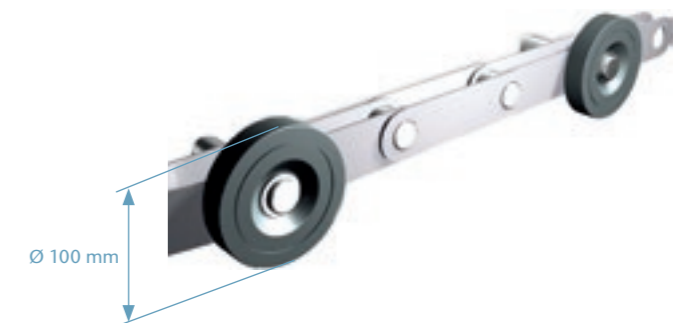
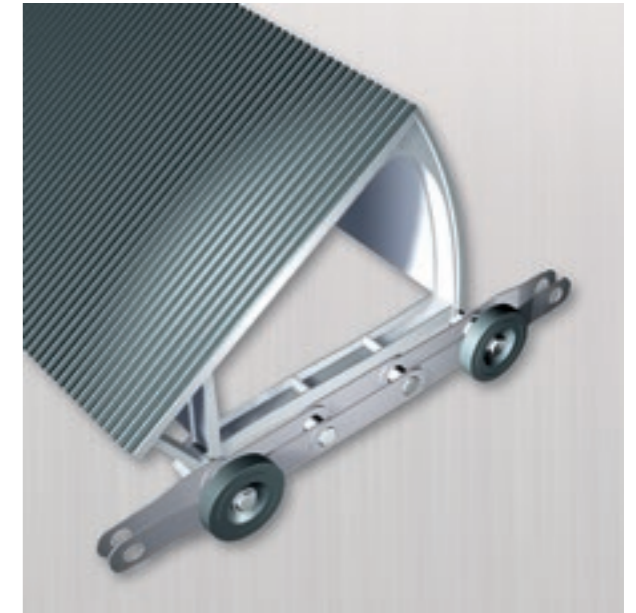

Figure 5.1 Step chain with outside rollers



Figure 5.2 Step chain with inside rollers

At KONE we take very seriously our commitment to eco-efficiency, which we define as the concept of creating better goods and services while using fewer resources and creating less waste and pollution. Eco-efficiency is therefore an integral part of KONE's processes and our objective is to lead the industry in eco-efficiency. Today we supply excellent Eco-efficient™ products and services, and constantly work at minimizing the carbon footprint of our own operations.

5.2 Energy consumption

KONE has developed measures and innovations to cut the energy consumption of escalators and autowalks. Our starting point is obtaining precise information on areas such as:

- Motor power, which is defined by the cut-off rises (the motor power needed per rise limitation) of an escalator platform
- Passenger usage (frequent or low use, leading to load profile calculations)
- Mechanical, electrical and structural energy-saving features
- Energy consumption of optional equipment (lighting, heating, cooling)
- Quality aspects (proper maintenance, adjustments for reduced friction).

In addition, our global manufacturing network has adopted ISO 14001, the most well-known and globally recognized environmental management system standard. Most of our manufacturing facilities and country organizations hold ISO 14001 certification, and KONE Corporation complied with ISO 14001 in early 2009.

To enhance the eco-efficiency of your operations, consider the options listed on the following pages. Many of the solutions described in this chapter are also available as easy to install retrofit packages.

KONE has developed an advanced energy consumption tool, that can be utilized to calculate the total energy consumption of the escalator or autowalk. This tool can be used to verify the impact of different operational parameters and product options to the total energy consumption. Please feel free to contact the local KONE sales organization for specific energy consumption figures and detailed analysis and recommendations.

KONE Direct Drive

The KONE-designed Direct Drive helps cut both operating costs and your building's carbon footprint. By replacing the conventional worm gear with the KONE Direct Drive, mechanical losses have been minimized, reducing the drive's energy consumption by up to 20%.

1. Energy management

Power feedback units

- Solutions for regeneration of power from the downward running of the passenger loaded escalator are available where an inverter is installed.
- Replaces brake resistors, which generate heat
- Technology for extensively used escalators

2. Operational mode

Star/Delta operation

- A conventional energy saving feature as basic option
- When there is low escalator traffic the motor is switched to Star-operation increasing the efficiency of the motor in no load and low load situations. When a certain number of passengers enters the escalator the motor reverts to Delta-operation
- Recommended for low load situations

Stop & Go operation

- The escalator stops running when not in use, almost no power consumption when escalator is stopped
- Can be combined with Star/Delta energy saving
- Recommended for low traffic or with long intervals of no passengers

Stand-by speed operation (by inverter control)

- Escalator runs at reduced speed with no passengers on the step band (changing from a nominal speed of 0.5 m/s to a stand-by speed of 0.2 m/s)
- Recommended for medium traffic or several peak and non-peak intervals
- Can be combined with Stop & Go, which provides additional energy savings

Traffic dependent operation

- The escalator is able to run automatically in the direction from where the first passenger is approaching
- When not in use the escalator is stopped
- Recommended for traffic conditions with low traffic or long intervals of no passengers
- The installation of a second escalator is not necessary as the solution enables automatic dual operation

3. Safety

Dynamic braking

- Electrical braking of escalator instead of mechanical braking
- Extends service intervals due to minimal brake pad wear
- Increases safety by ensuring constant braking distances independent of passenger loading and travel direction
- Requires frequency converter and a special safety circuit

4. Mechanical systems

Lubrication-free step chain

- Permanent greased and sealed chain links do not require extra lubrication with oil
- No oil consumption; the truss stays oil-free
- Reduced wear of chain links and bushings
- Reduced fire risk

5. Aesthetic features

LED lighting

- Extended service life – last up to 10 times longer than fluorescent lighting
- Energy savings: up to 80% more energy efficient than fluorescent lighting

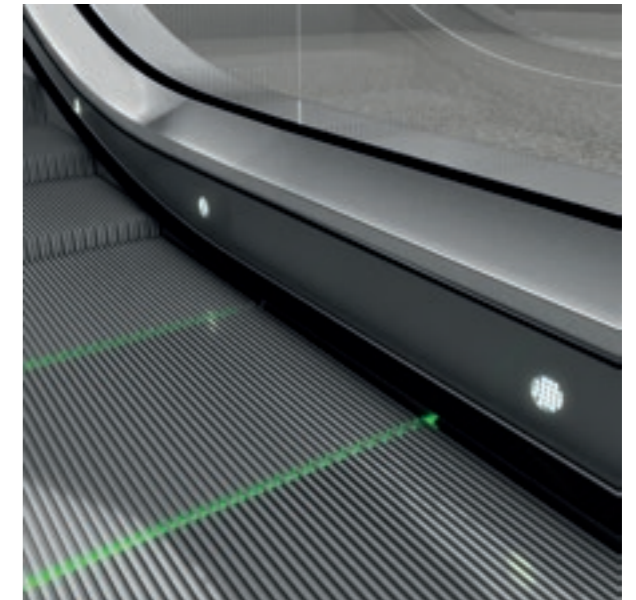
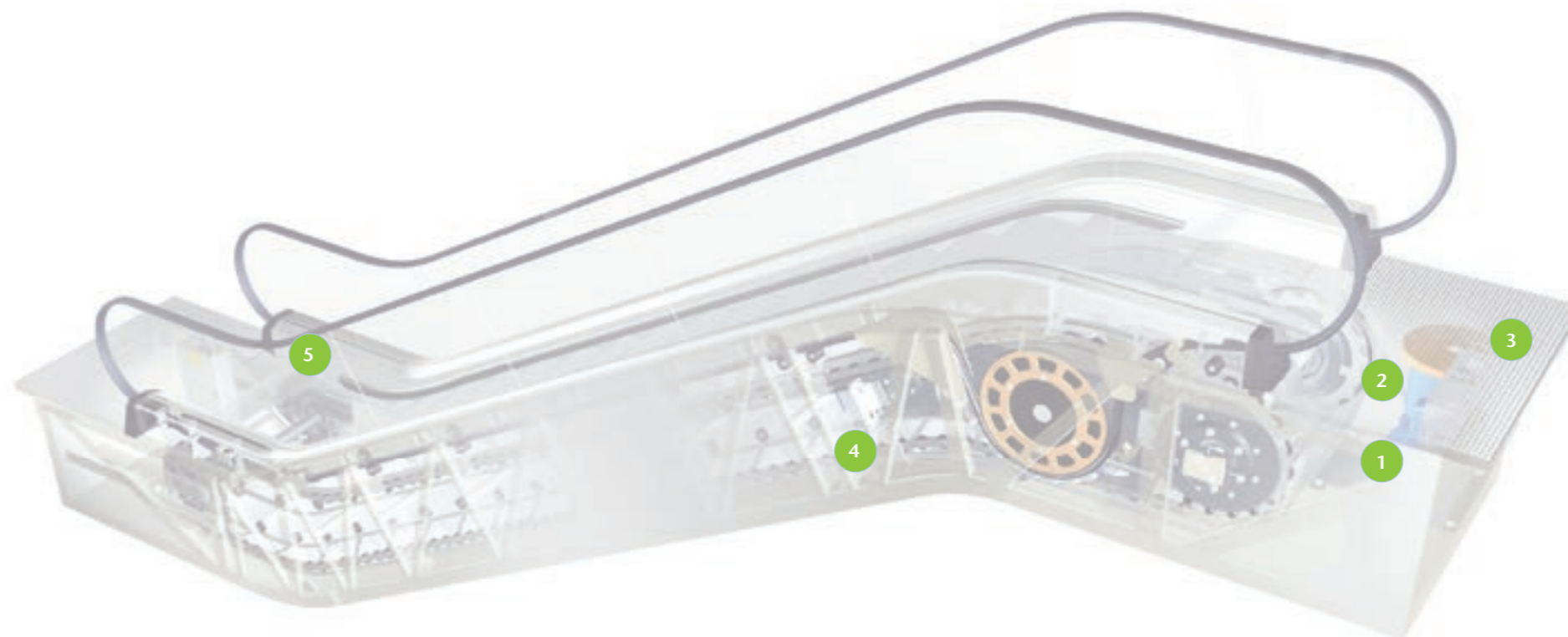

Figure 5.3 LED skirt spotlighting



5.3 Step width

Escalators

Escalators are generally available in three step widths: 600, 800 and 1000 mm.

600 mm step width

- Allows only one adult passenger to stand on each step
- Should only be selected where space for an escalator is restricted, as it is uncomfortable for passengers and presents an old-fashioned appearance
- As space is very restricted between the balustrades, is only suitable for installations where passengers will not be carrying large shopping bags or luggage

800 mm step width

- Allows one adult passenger and a small child, or one adult passenger with shopping bags or luggage (i.e. 1.5 passengers) to stand on each step
- Suitable for medium or low usage installations, such as shops

1000 mm step width

- Allows two adult passengers to stand on each
- Maximizes transport capacity for high usage installations such as large department stores, shopping malls, airports and railway stations

EN 115-1 The maximum and minimum permitted step widths under EN 115-1 are 1100 mm and 580 mm respectively. In Europe, the escalator manufacturers have standardized on three step widths; 600 mm, 800 mm and 1000 mm. These widths are permitted at any step band speed, angle of inclination or vertical rise.

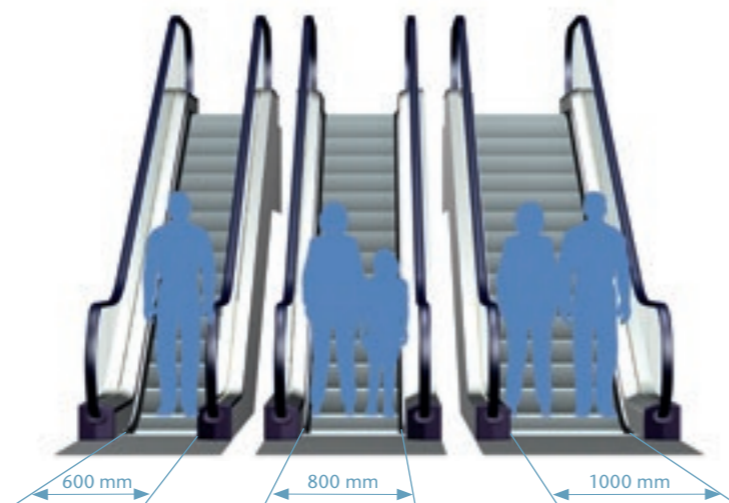

Figure 5.4 Escalator step widths

Horizontal autowalks

KONE horizontal autowalks with an angle of inclination of up to 6° are available with pallet widths of 1000 mm, 1200 mm and 1400 mm.

- Generally available in pallet widths of 1000 mm, 1200 mm and 1400 mm
- As the majority of autowalks are for high usage installations, such as airports, a 1400 mm pallet width is always preferable
- 1400 mm pallet allows two adult passengers to stand on each one and thereby maximizes the transport capacity
- 1000/1200 mm pallet widths are suitable for medium or low usage installations, such as smaller airports or hospitals
- 1000/1200 mm pallet width allows one adult passenger and a small child to stand on each pallet or one adult passenger with shopping bags or luggage.

EN 115-1 Autowalks with an angle of inclination of up to 6° are permitted to have larger pallet widths, provided that their pallet band speed does not exceed 0.75 m/s.

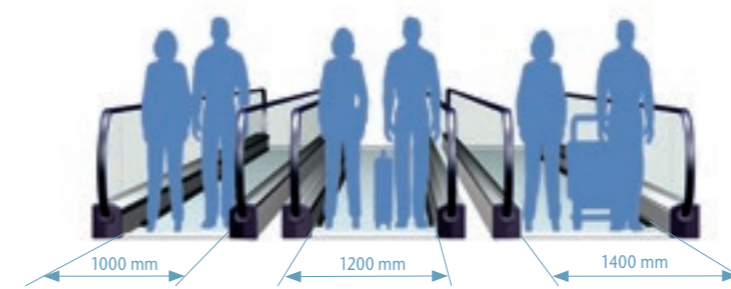

Figure 5.5 Horizontal autowalk pallet widths

Inclined autowalks

KONE inclined autowalks have 800 mm, 1000 mm and 1100 mm pallet widths available.

A 1000 mm pallet width is recommended for evacuation purposes as, if an inclined autowalk with a pallet width of 800 mm is stopped, shopping trolleys could easily create a blockage on the autowalk and prevent safe evacuation.

EN 115-1 The minimum and maximum permitted pallet widths under EN 115-1 for autowalks with an angle of inclination in excess of 6° are 580 mm and 1100 mm respectively. In Europe, escalator manufacturers have standardized on three pallet widths for autowalks with an angle of inclination in excess of 6°; 800 mm, 1000 mm and 1100 mm.

The width of the shopping trolley or baggage cart and contents should be at least 400 mm less than the pallet width, to leave sufficient space for passengers to pass by.

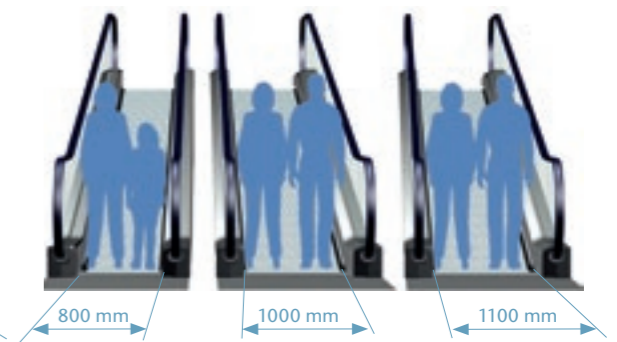

Figure 5.6 Inclined autowalk pallet widths

5.4 Nominal speed

Escalators

The speed of your escalator will have a significant effect on its transport capacity. However, it's not as straightforward as selecting the fastest escalator speed possible in order to move as many people as possible within a certain time. In some buildings a slower speed is preferable. In general, three speeds are available: 0.5, 0.65 and 0.75 m/s:

0.50 m/s

- Optimal speed for the retail environment
- Combines sufficient transport capacity, optimal safety and minimum space requirements
- Gives customers an opportunity to “window shop” from the escalator

0.65 m/s

- Recommended for the public transportation environment such as railway stations and metro stations
- Optimal speed for situations where passenger arrivals are intermittent

0.75 m/s

For extreme transportation situations only such as high-rise escalators. Not recommended by KONE for two reasons:

- As indicated in section 4.2, as the speed increases, people hesitate longer before stepping onto the escalator, thus reducing the effective transport capacity
- This speed is less comfortable for elderly passengers and children

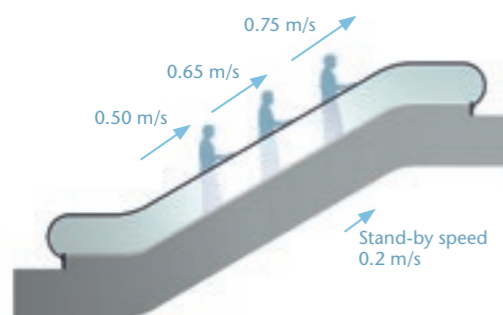

Figure 5.7 The nominal speeds for escalators and autowalks

EN 115-1 The maximum permitted step band speed under EN 115-1 is 0.75 m/s. However, this speed is only appropriate for high-rise, heavy-duty escalators (i.e. mass transit systems) and, as such, is not applicable to the majority of escalators.

- The step band speed is normally 0.5 m/s, which is permitted at any angle of inclination or vertical rise (max 35°)
- For heavy-duty escalators in public service environments, a step band speed of 0.65 m/s is allowed

Escalators with step band speeds in excess of 0.5 m/s are subject to the following restrictions:

- The angle of inclination must not exceed 30°
- There must be a minimum of three horizontal steps (1200 mm) at each landing
- The upper transition radius must be a minimum of 1.5

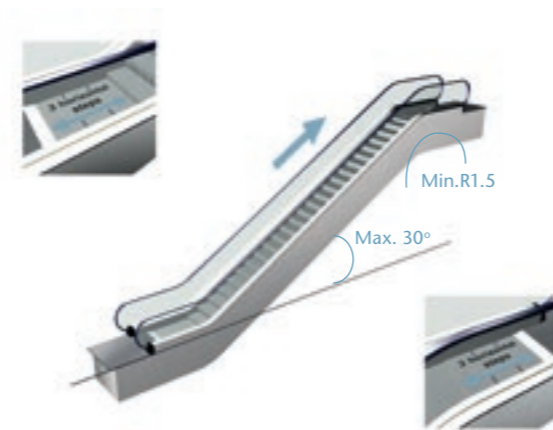

The use of both shopping trolleys and baggage carts on escalators is unsafe and not permitted due to potential misuse, overloading and width restriction. Where shopping trolleys and/or baggage carts are available in the area around escalator installations, suitable barriers should be provided to prevent access with them.

Horizontal autowalks

The three speeds available are:

- 0.5 m/s – for short autowalks or when other considerations warrant a slower speed and comfort of use
- 0.65 m/s – normally specified for autowalks as it offers a good compromise between passenger capacity, comfort and energy efficiency
- 0.75 m/s – occasionally specified for heavy-duty and/or long autowalks to increase passenger capacity and reduce travel time.

In the interests of passenger safety and the service life of the autowalk, the standard 0.65 m/s pallet band speed is recommended whenever possible. The speeds of KONE escalators and autowalks are summarized in [Table 5.1](#).

Inclined autowalks

0.5 m/s is the standard speed which is normally used for inclined autowalks, as these are usually installed in a commercial environment and occasionally in railway stations.

EN 115-1 The maximum permitted pallet band speed under EN 115-1 is 0.75 m/s. The code also permits a deviation above a nominal speed up to 0.90 m/s provided the width of the pallets or the belt does not exceed 1.1 m, and that the landings and pallets move horizontally for at least 1.6 m before entering the combs.

The use of suitably designed shopping trolleys (according to EN 1929-2 and EN 1929-4) and baggage carts on autowalks is permitted.

Table 5.1 Summary of the speeds available with KONE escalators and autowalks

	0.50 m/s	0.65 m/s	0.75 m/s
Commercial escalators	Standard	Not available	Not available
Infrastructure escalators	Standard	Recommended	Available but not recommended
Horizontal autowalks	Optional	Recommended	Optional
Inclined autowalks	Standard	Not available	Not available

5.5 Inclination of escalators

KONE escalators are available with three angles of inclination: 27.3°, 30° and 35°.

27.3° inclination

- The normal angle for a staircase
- Ideal when the escalator is installed adjacent to a staircase as it provides a good alignment between the escalator truss and the staircase
- Recommended for infrastructure escalators

30° inclination

- This popular inclination offers a good compromise between passenger comfort, safety and the overall length of the escalator
- Used in both commercial and infrastructure applications

35° inclination

- Offers the most compact dimensions
- Preferable when space is restricted on site
- Offers the lowest capital cost for a given vertical rise
- Common in retail applications

If other inclinations are required, please contact the local KONE sales representative.

EN 115-1 The maximum angle of inclination under EN 115-1 is 35°, subject to the following restrictions:

- The vertical rise must not exceed 6000 mm
- The step band speed must not exceed 0.5 m/s

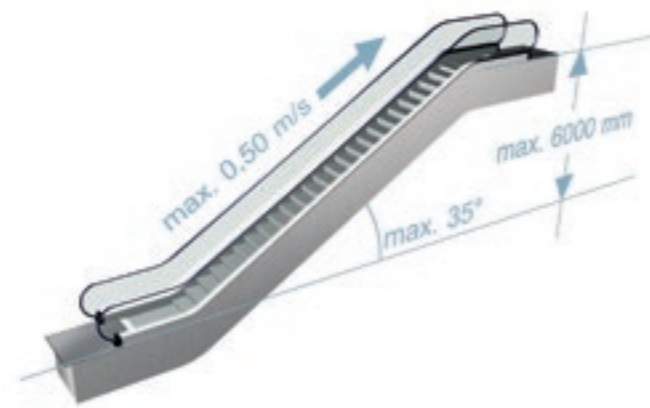

Escalators with a 30° angle of inclination or less are permitted at any step band speed (up to the EN 115-1 maximum of 0.75 m/s) or vertical rise.

For speeds above 0.65 m/s, the minimum lower radius of 2.0 and the minimum upper radius of 2.6 are mandatory, with a minimum of 4 horizontal steps.

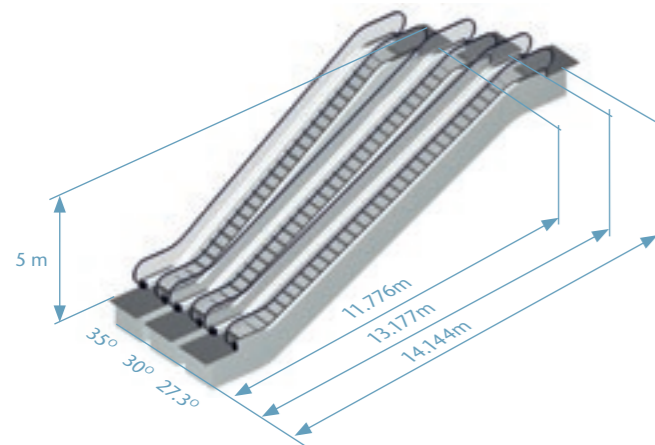

Figure 5.8 The relationship between inclination angle and overall vertical/horizontal dimensions of escalators.

5.6 Inclination of autowalks

For KONE autowalks, four angles of inclination are available: 0°, 10°, 11° and 12°.

Horizontal autowalks

By definition, a horizontal autowalk has a 0° inclination, although we also provide horizontal autowalks with a slight inclination for uneven surfaces up to 6°. A horizontal autowalk is normally used in airports or exhibition centers for the horizontal movement of passengers.

Inclined autowalks

Inclined autowalks tend to be used in preference to escalators in buildings where shopping or baggage trolleys are used and need to be transported by passengers between two floors, for example railway stations or supermarkets. When trolleys are to be transported, special trolley rollers need to be used. The use of suitably designed shopping trolleys (according to EN 1929-2 and EN 1929-4) and baggage carts on inclined autowalks is permitted.

10°, 11° and 12° inclinations are possible. When space is restricted on site, 12° autowalks are preferable as they offer the most compact dimensions. The most frequently installed inclination is 12°.

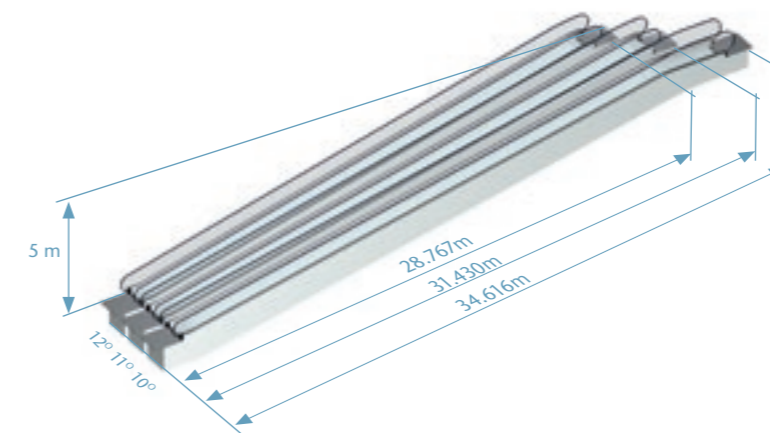

Figure 5.9 The relationship between inclination angle and overall vertical/horizontal dimensions of inclined autowalks.

5.7 Horizontal (level) steps/pallets

Horizontal (level) steps are required at each landing of an escalator to enable passengers to safely board and disembark the moving step band. They allow passengers to steady themselves and position their feet correctly on the steps before reaching the transition curve into the inclined section. When disembarking, horizontal steps allow passengers to safely step off the moving step before their feet touch the combs. Escalators must be equipped with horizontal steps on both ends.



Figure 5.10 Horizontal steps enable a passenger to step safely on and off the escalator.

Escalators

EN 115-1 The minimum number of horizontal steps at each landing under EN 115-1 is two. Note that the vertical rise must not exceed 6000 mm. EN 115-1 also specifies that the step speed must not exceed 0.5 m/s (see Figure 5.11).

For greater rises and step band speeds up to 0.65 m/s, three horizontal steps (1200 mm) at each landing are required.

The exceptions to this rule are escalators with a step band speed in excess of 0.65 m/s. These require a minimum of four horizontal steps (1600 mm) at each landing. At nominal speeds above 0.5 m/s and not more than 0.65 m/s or rises above 6 m this length should be at least 1200 mm, i.e. 3 horizontal steps.

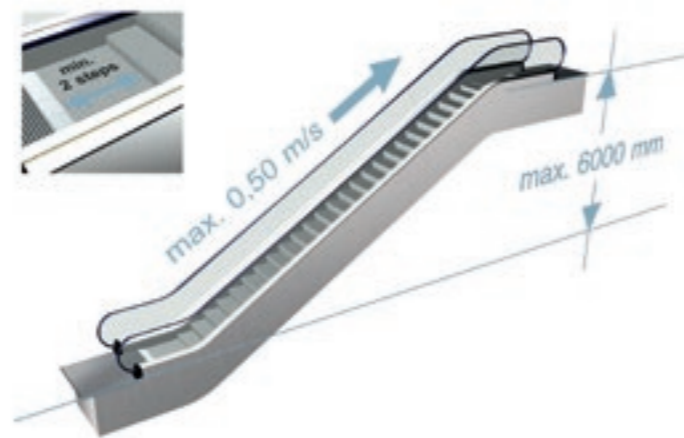

Figure 5.11 Vertical rise and speed of an escalator with two horizontal steps.

Inclined autowalks

Inclined autowalks must be equipped with horizontal pallets for the same reasons as escalators. However, there is a choice whether you wish to install these only at the top end or at both ends. Inclined autowalks have one horizontal pallet at top, and none at the bottom, as standard.

EN 115-1 Autowalks with an inclination of up to 6° do not have any horizontal pallets (unless the autowalk is horizontal) or a transition radius at either landing.

Autowalks with an angle of inclination between 6° to 12° require one horizontal pallet (400 mm) as a minimum at their upper landing.

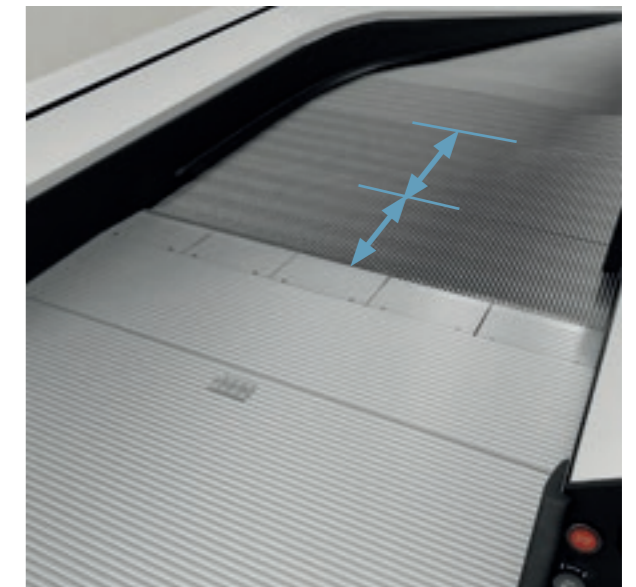
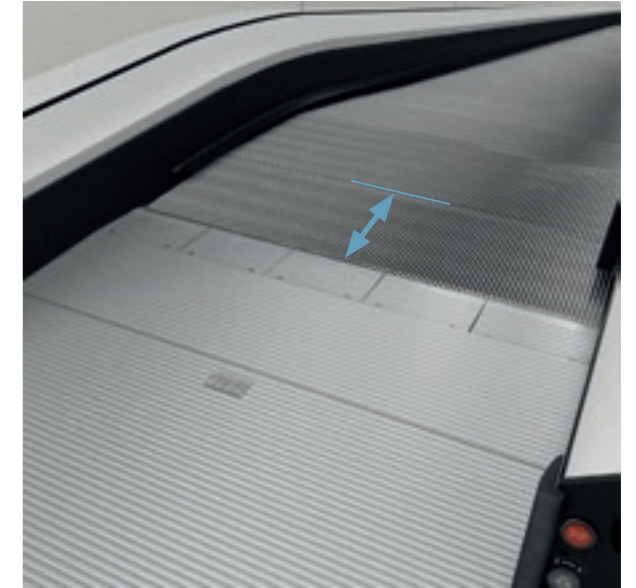

Figure 5.12 The number of horizontal pallets required for inclined autowalks varies with the speed and inclination (one horizontal pallet on the top, two horizontal pallets on the bottom picture).

For both escalators and inclined autowalks, you might like to consider a higher number of horizontal steps/pallets than is recommended by the EN 115-1 code, to increase passengers' comfort. This is particularly relevant for passengers stepping onto a descending escalator before it enters the transition curve.

5.8 Vertical rise (travel height)

Table 5.2 gives an overview of the common vertical rise possibilities for different building segments. For actual product information please refer to the [product vs. segment matrix](#) as well as the [product-specific modules](#) in the other sections of this Planning Guide.

For horizontal autowalks the minimum length is 10 m and the maximum length 250 m. We recommend not to use a horizontal autowalk longer than 75 m as during evacuation the balustrade is too high for safe evacuation of passengers on the autowalk.

Table 5.2 The most common vertical rises used in different buildings (others are possible)

Equipment	Rise
 Retail/office/hotel/medical escalators	2 to 12 m
 Leisure escalators	2 to 18 m
 Airport escalators	2 to 12 m
 Public transportation escalators	3 to 40 m
 Inclined autowalks	1 to 10 m

Escalators and inclined autowalks

EN 115-1 EN 115-1 puts no limit on the vertical rise of an escalator. However, for vertical rises in excess of 6 m, the following restrictions apply:

- The angle of inclination must not exceed 30°
- There must be a minimum of three horizontal steps (1200 mm) at each landing
- An auxiliary brake must be fitted

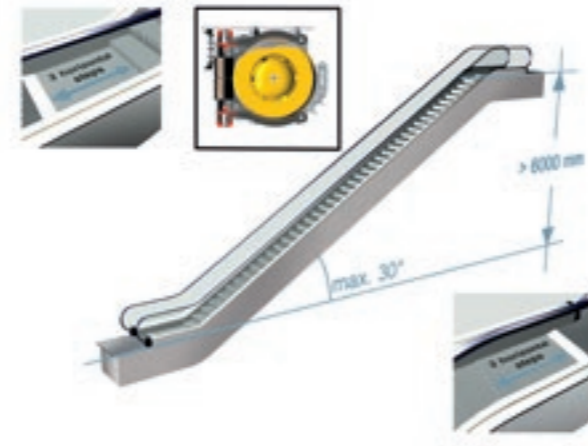

In addition, possible building requirements come into play when exceeding a certain level within an atrium, such as balustrade height. These should be dealt with case by case.

5.9 Transition radii

Various transition radii are available, depending on the environment and the space availability. Table 5.3 displays our recommended combinations. In the table, 1.5/1.0 refers to a transition radius of 1.5 at the top and 1.0 at the bottom. Please also note that the choice of transition radii is linked to inclination, speeds and the number of horizontal steps. You are advised to consult the [product-specific module](#) to find out what is available per product type.

EN 115-1 In EN 115-1, the radius of curvature in the upper transition from incline to horizontal shall be:

- At least 1.0 for nominal speeds $v \leq 0.5$ m/s (inclination of max 35°)
- At least 1.5 for nominal speeds $0.5 \text{ m/s} < v \leq 0.65$ m/s (inclination of max 30°)
- At least 2.6 for nominal speeds $v > 0.65$ m/s (inclination of max 30°)

The radius of curvature in the lower transition from incline to horizontal of the escalator shall be at least 1.0 up to 0.65 m/s; and at least 2.0 above 0.65 m/s.

Table 5.3 Recommended transition radii for escalators

-  **Commercial escalators**
- 1.0/1.0 (Available 30°, 35°
2 horizontal steps)
 - 1.5/1.0 (Available 30°
2 or 3 horizontal steps)

-  **Infrastructure escalators**
- 1.5/1.0 (Available 27.3°, 30°, 35°
2 or 3 horizontal steps)
 - 2.7/2.0 (Available 27.3°, 30°
3 or 4 horizontal steps)
 - 3.6/2.0 (Available 27.3°, 30°
3 or 4 horizontal steps)

5.10 Operational modes

The operational mode describes the way the unit is operated by the controller.

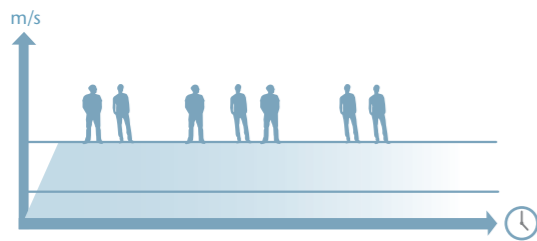

A Continuous:

The unit is started by a key switch and runs continuously in the selected direction until stopped by a key switch or the emergency stop.

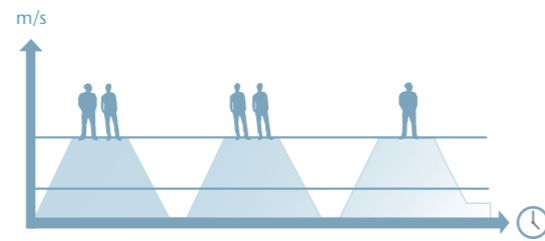

B Stop & Go:

This mode is the same as Continuous except that the unit stops after a pre-selected time if no passengers are detected. If a passenger is then detected at either landing, the unit restarts in the pre-selected direction.

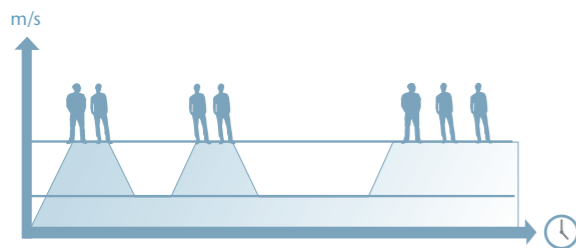

C Stand-by speed:

This mode of operation is the same as Stop & Go except that the unit is slowed down to a stand-by speed by the inverter instead of being stopped. The stand-by speed is approximately 40% of nominal speed, namely 0.2 m/s for an escalator normally operating at 0.5 m/s.

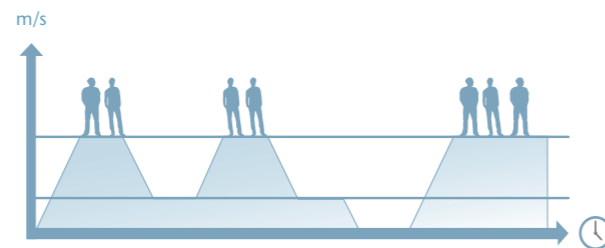

B+C:

A combined B+C function is also possible.

See also [chapter 5.2](#) which deals with the eco-efficiency of certain operational modes.

Figure 5.13 Selecting the correct operational mode is essential for energy reduction.

Passenger detection

The passenger detection feature is used for all operational modes except continuous mode. The most common means of passenger detection are photocells or radar devices.

Traffic lights

Traffic lights have to be fitted visibly at both landings for Stop & Go and passenger control operation.

EN 115-1 In the case of escalators or autowalks starting automatically, a clearly visible signaling system such as traffic lights is specified under EN 115-1 to indicate to the user whether the escalator or autowalk is available for use, and its direction of travel.

The code also specifies that escalators or autowalks which start or accelerate automatically when a user steps onto them (stand-by operation) are required to move at least 0.2 times the nominal speed when the person reaches the comb intersection line and then should accelerate at less than 0.5 m/s².

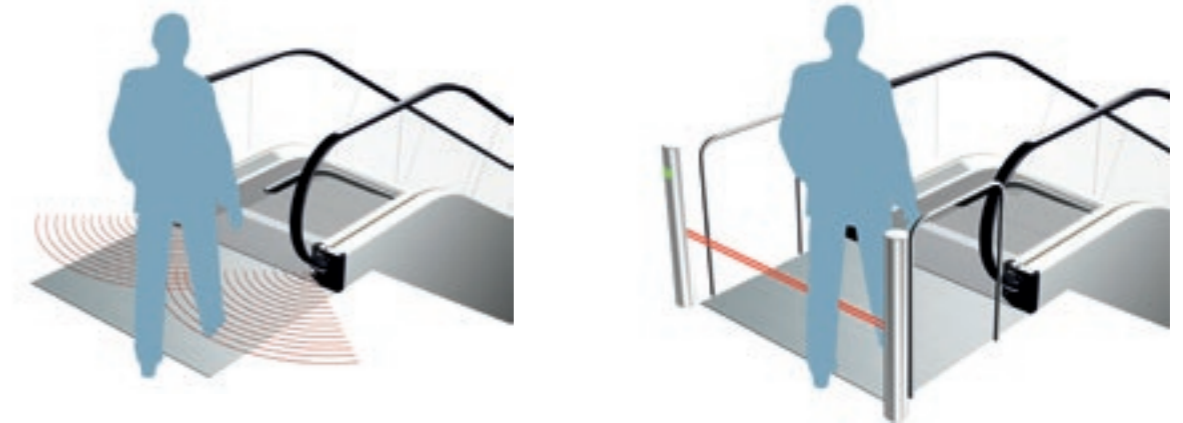

Figure 5.14 Passenger detection by radar or a photocell

5.11 Type of balustrade

Standard glass balustrade

- Suitable for shops and airports
- Slim handrail base profile for a visually light appearance preferred by architects and interior designers in modern buildings
- Balustrade panels:
 - 10 mm thick clear tempered glass
 - Self-supporting without the need for support mullions
 - Separated into standard lengths
 - Neatly butt up to each other without cover strips
- Can be supplied with one balustrade in glass and the other in stainless steel
- Alternatively sandwich stainless steel panels can be used if required



Figure 5.15 A glass balustrade is an attractive option for shops and airports

Vertical or inclined solid balustrade

- Particularly suitable for public transportation, semi-outdoor or fully outdoor installations
- More durable and vandal-resistant than a glass balustrade
- Normally manufactured from satin stainless steel
- Only available with a 1000 mm height and not on all KONE escalator types, nor for KONE autowalks. (Please refer to the [product-specific modules](#))



Figure 5.16 A solid inclined balustrade is more suitable for infrastructure escalators

Extended balustrade

- Often used for Stop & Go, as the sensors can be easily located in the newel end
- Also used when an escalator is installed in an open wellway, where there is no floor to the sides of the access covers. In this case the building's static balustrades (not provided by KONE) must be turned through 90° to provide a safe interface with the escalator's balustrades. As this type of interface generally looks untidy, extended balustrades are available as an option (1000 mm) at either the top landing or at both landings
- Allows static balustrades to neatly interface with the side of the escalator balustrade to offer a more aesthetically pleasing solution
- Is not available for all products; please refer to the product-specific modules.



Figure 5.17 Standard arrangement without extended balustrade requires 90° static railings to be installed for safety reasons

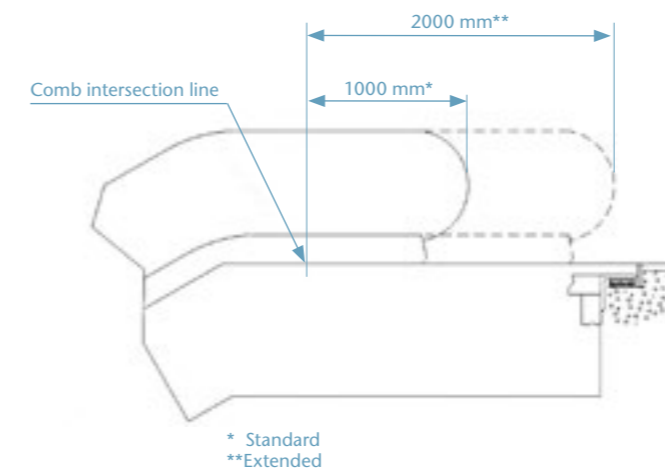

Figure 5.18 Different extended balustrade lengths

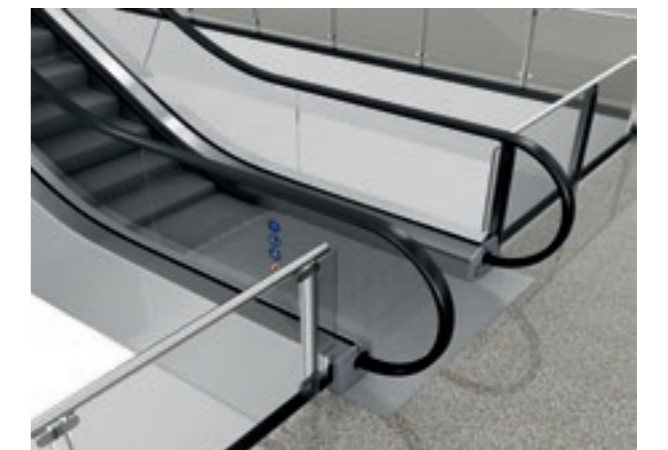

Figure 5.19 An extended balustrade allows railings to neatly butt against the escalator balustrade

5.12 Balustrade height

Balustrade height is measured vertically to the top surface of the handrail from the nose of the steps on the inclined section and from the finished floor level at the landings. The standard balustrade height is 900 mm.

As an alternative, high balustrades are available. The higher balustrade increases safety for adults, as the higher the balustrade, the less likely a passenger is to fall over the balustrade if they lose their balance. It also offers a better interface with the railings around the escalator wellway as these must be a minimum of 1100 mm high. However, a higher balustrade makes the handrail more difficult to reach for small children and is, therefore, less safe for them. 1100 mm balustrades are commonly used on high-rise escalators in atriums. The solid vertical and inclined balustrade is only available with a height of 1000 mm.

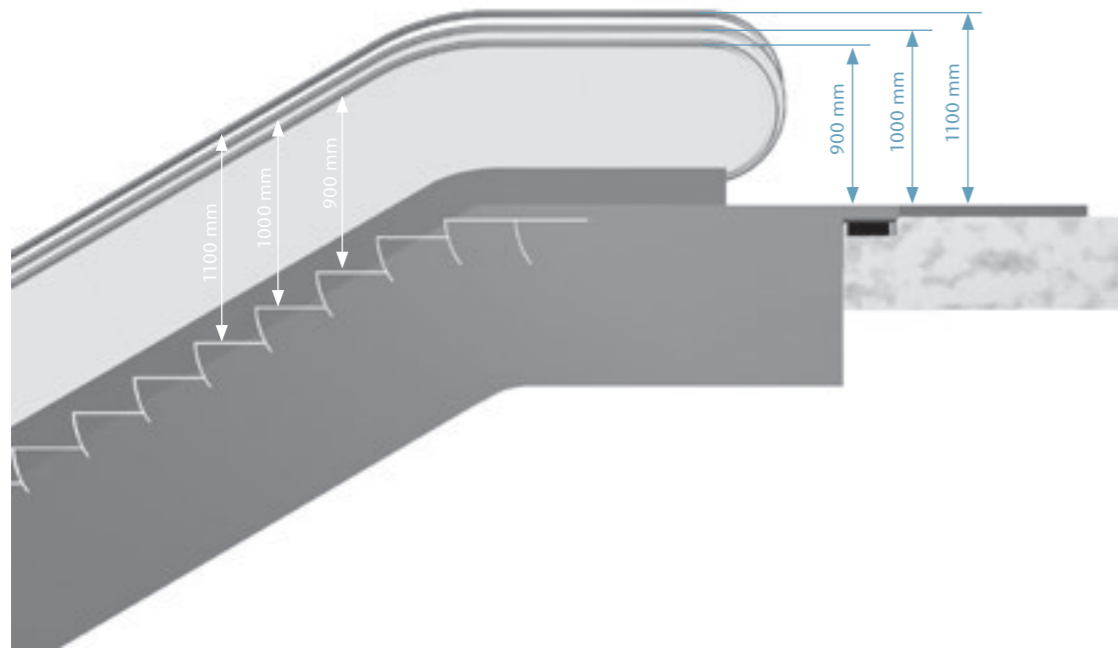

Figure 5.20 Balustrade height alternatives

SUMMARY

With the information gathered so far in this Planning Guide, you should be able to specify a certain configuration for your escalators or autowalks. This should include:

- Load profile
- Energy consumption
- Step width, speed and inclination
- Horizontal steps/pallets
- Vertical rise
- Operational modes
- Type and height of balustrade.

The construction of your chosen equipment depends on the prevailing standards and regulations in your country, which are generally EN 115-1, although local standards might apply.

Fiera Milano Fairground
Milan, Italy
28 KONE horizontal autowalks

6. CONSTRUCTION CONSIDERATIONS

At KONE the safety of passengers and service engineers using and maintaining escalators and autowalks is of paramount importance. To ensure their safety, it is therefore imperative that your escalator or autowalk is constructed and installed in full compliance with an internationally recognized safety standard.

The objective of this chapter is to present you with the EN 115-1 code restrictions and considerations that you should take into account when designing your project and integrating escalators and autowalks within the project.

This chapter clarifies issues such as:

- Passenger circulation area
- Handrail and headroom clearance
- Protective barriers
- Head guards
- Railings



Bras Basah station
Singapore
12 KONE escalators

6.1 Passenger circulation area

To ensure that passengers can safely board and disembark the escalator or autowalk, a clear passenger circulation area must be available at each landing to allow their unimpeded movement. The passenger circulation areas for single and adjacent escalators are as follows.

EN 115-1

- The width of the unrestricted area shall at least correspond to the distance between the outer edges of the handrails plus 80 mm on each side. The depth shall be at least 2.50 m measured from the end of the balustrade (Figure 6.1a). This is always the case with KONE units.
- It shall be permissible to reduce it to 2.0 m if the width of the unrestricted area is increased to at least double the distance between the outer edges of the handrails (Figure 6.1b).

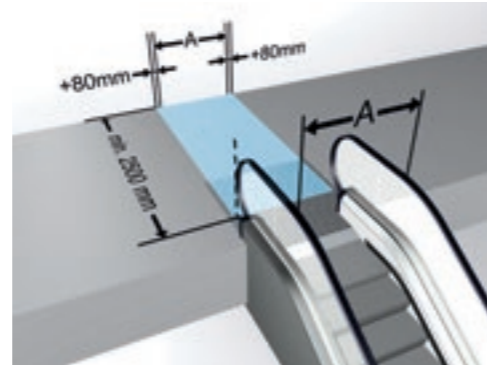

a)

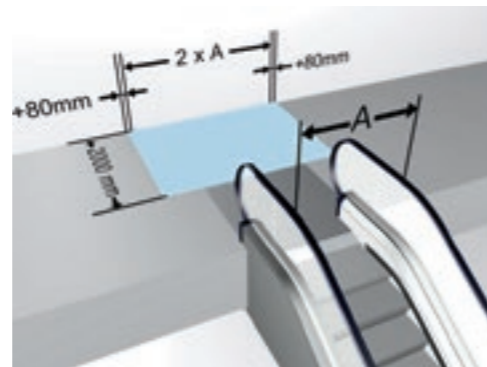

b)

Figure 6.1 a) and b)
Passenger circulation area for single escalators
A = distance between handrail outer edges

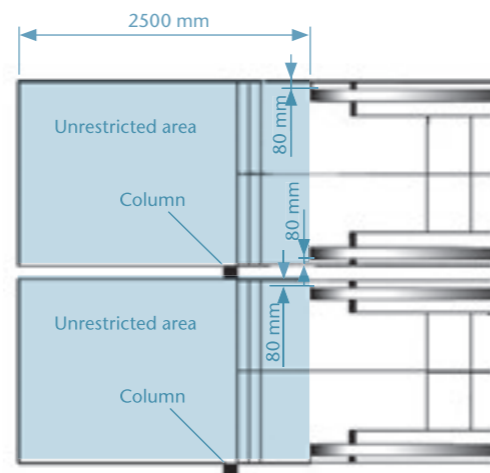

Figure 6.2 Passenger circulation area for parallel escalators

For parallel escalators or autowalks the recommended clear passenger circulation area is shown in Figure 6.2.

NOTE: For autowalks where shopping trolleys or baggage carts are used, we recommend you to increase the passenger circulation area in front of the autowalk as much as possible, for example to 5 meters, this to increase the efficient people flow within the building.

6.2 Minimum handrail and headroom clearance

EN 115-1

The key points regarding handrail and headroom clearance are described below (see Figures 6.3 and 6.4).

A: If the distance from the end line of the handrail to the edge of the ceiling or adjacent escalator truss is less than 400 mm, an apex/head guard (see chapter 6.4) is required (i.e. 380 mm from the edge of the truss to the edge of the ceiling or adjacent escalator truss).

B: The handrail clearance must be maintained for a minimum height of 2100 mm for the entire 80 mm or more from the outer edge of the handrail to the wall or obstacle. The smaller clearance here compared to what is required above the step band allows escalators and autowalks to be installed under an arched roof.

C: For adjacent escalators, the distance between adjacent escalator handrails shall be at least 160 mm. Please note that this distance is always above 160 mm with KONE escalators and autowalks.

D: 2300 mm minimum headroom is required above step band.

E: 80 mm minimum clearance is required between the outer edge of the handrail and walls or other obstacles. Please note that this distance is always more than 80 mm with KONE escalators and autowalks.

Product-specific information on handrail and headroom clearance will be provided to you by KONE.

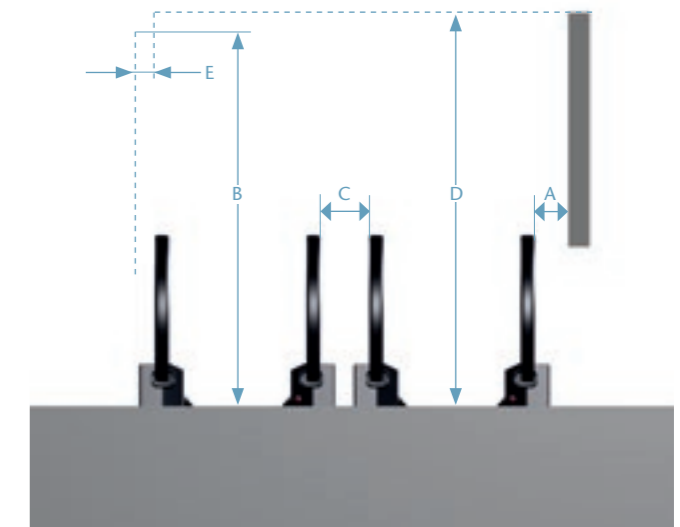

Figure 6.3 Minimum free area around escalators and autowalks

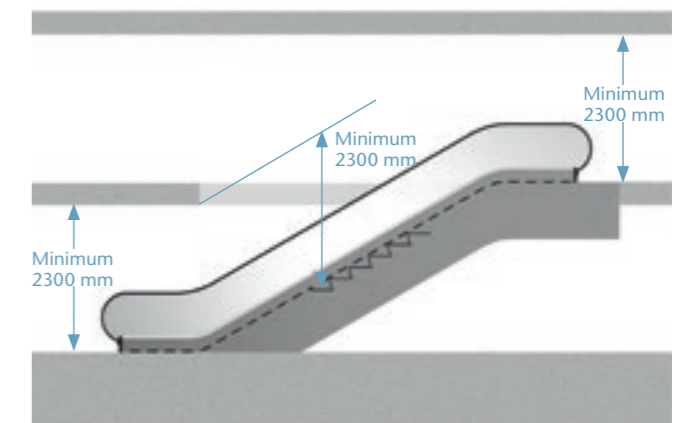

Figure 6.4 Minimum headroom clearances

6.3 Protective barriers

Appropriate structural measures should be installed to prevent people from accessing escalators or autowalks from the side. Protective barriers and guards are to be provided on the balustrades where necessary. To prevent misuse and contact to the building structures, several deflectors have to be installed as mandatory.

EN 115-1

- Head guards/apex guards (see chapter 6.4)
- Deck guards need only be provided when KONE parallel escalators are touching. If there is a gap between the escalators this deck guard is the responsibility of the customer
- Anti-slide cones (on solid inclined balustrades only). These are mandatory whenever a high intermediate decking is placed between escalators or between a wall and a balustrade
- Anti-climb device. This is provided where it is possible for people to come into contact with the outer edge of a handrail at a landing and could be drawn into a hazardous situation, such as toppling over a balustrade (see Figure 6.7).

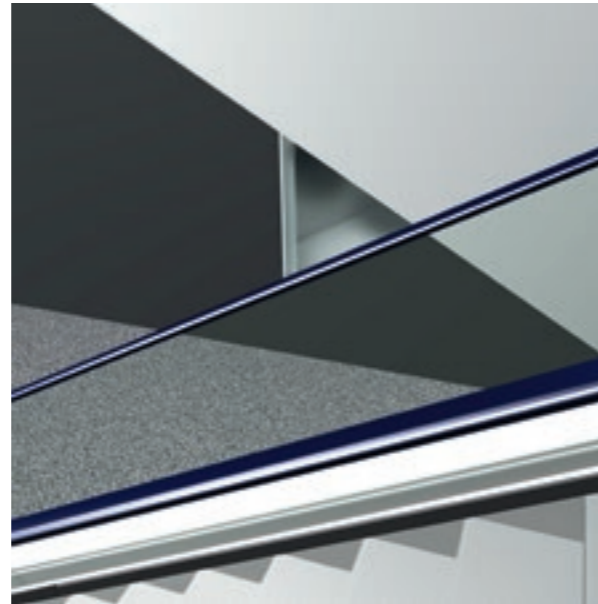

Figure 6.5 Head guard



Figure 6.6 Anti-slide cones

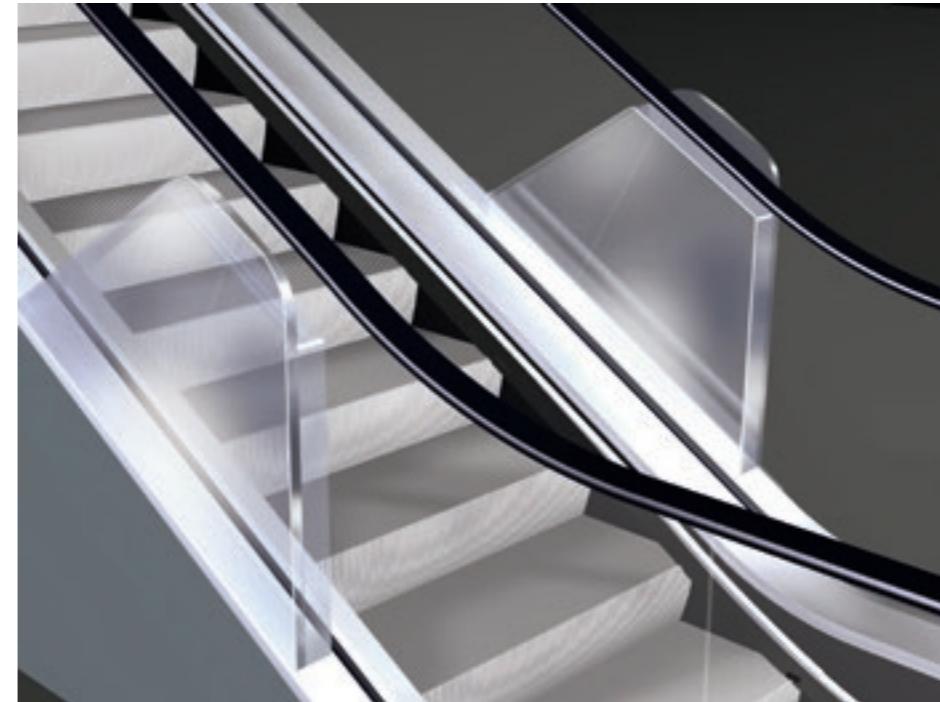

Figure 6.7 Anti-climb device



Figure 6.8 Deck guard

6.4 Head guards

Head/apex guards prevent passengers from getting trapped between the balustrade and building structure or other equipment. It is important that you install head and deck guards as follows.

EN 115-1

A: Ceiling intersection head guards are required if the distance between escalators and floor is less than 400 mm from outer edge of handrail.

B: Escalator truss intersection head guards are required if the distance between escalators is less than 400 mm from outer edge of handrail to the truss of another escalator.

C: All head guards must be installed, which is no less than 0,30 m in height, no presenting any sharp cutting edges, placed above the handrail level and extend at least 25 mm below the lower edge of the handrail.

NOTE: Refer to local governing codes that may supersede dimensions (A, B, and C) described above.

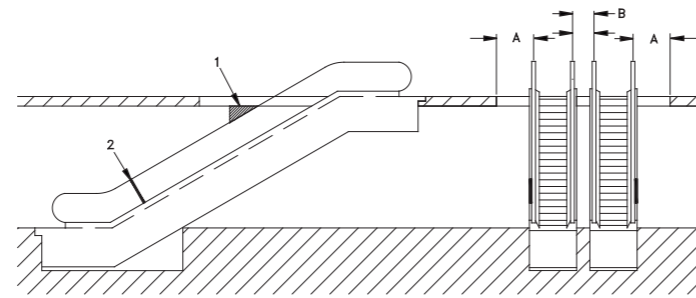

Figure 6.9 Head guards for parallel escalator

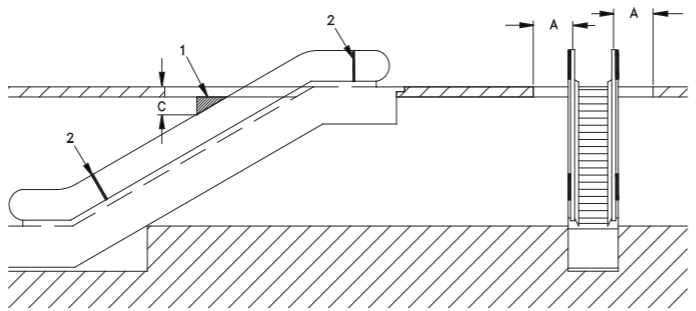

Figure 6.10 Head guards for single escalator

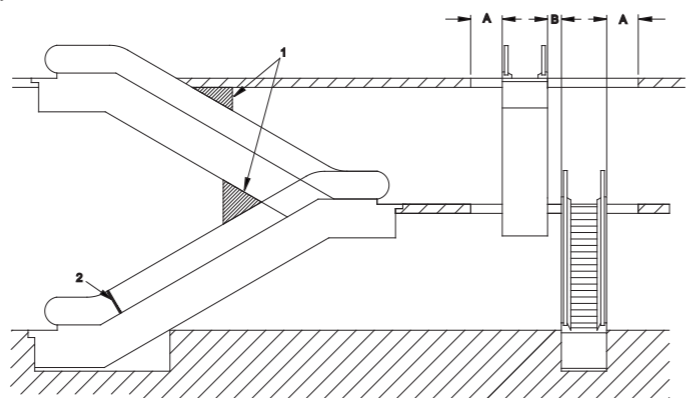

Figure 6.11 Head guards for scissored escalators

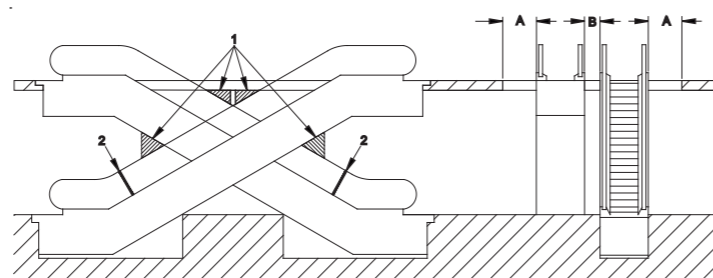

Figure 6.12 Head guards for criss-cross escalators

1= head guard
2= anti-climb device

6.5 Customer railings

Protective railings are to be fitted by the customer at the accesses to the escalators and autowalks to close the gap between the escalator and the atrium.

EN 115-1 The distance to the handrail of the escalator or autowalk must be at least 80 mm. Barriers should also be provided in between escalators if they are not touching.

Where shopping trolleys and baggage carts are available in the area around escalators, suitable barriers need to be provided. It is not the escalator provider's but the general contractor's responsibility to fit these railings.

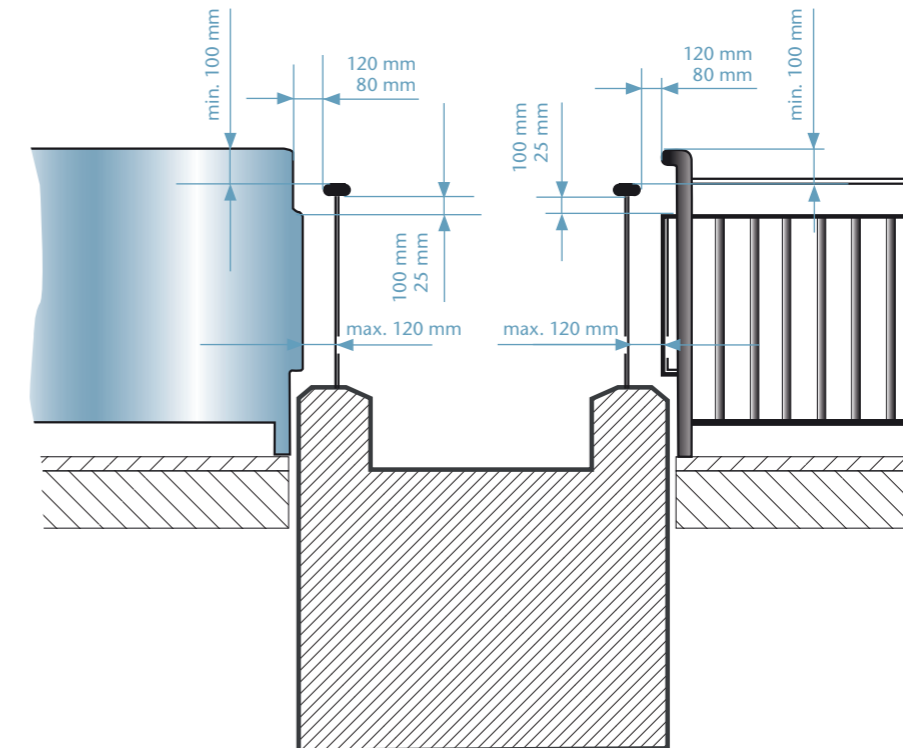

Figure 6.13 Clearances for customer railings according to EN 115-1

SUMMARY

In this chapter we looked at considerations surrounding the construction of the escalator or autowalk, such as:

- Passenger circulation area
- Handrail and headroom clearance
- Protective barriers
- Head guards
- Customer railings

The preparation of the site is covered in the next chapter.

*National Grand Theatre
Beijing, China
36 KONE escalators*



7. PREPARING THE SITE

Modern escalators and autowalks contain a lot of vulnerable electrical and electronic components. If the storage and working areas are not clean, dry and protected from the weather, the equipment can get ruined, even before it is installed.

It is therefore vital that the building site is thoroughly prepared in advance before the escalator or autowalk arrives at the site. Ideally, all discussions surrounding site preparation should take place prior to tender. This ensures that both parties are clear on who is responsible for what areas of the installation procedure. In addition the right protection of our products needs to be in place after installation and before final assembly and commissioning.

Also bear in mind that every installation is different. For some installations, additional requirements to the standard ones presented here may apply. These should be discussed during site visits. The building contractor also benefits from these discussions as disagreements over areas of responsibility are avoided, thus ensuring that the project proceeds smoothly within budget and without delays.

Basically the building contractor needs to take responsibility for the following:

- Prepare the mountings – the building needs to be able to resist the weight of the escalator, which can be between 4 and 10 tons, depending on the rise
- Respect the dimensions on KONE drawings – tolerances of KONE layout drawings are +/- 20 mm
- Levelling accuracy of floor – finish floor level markings on each floor are required close to the escalator shaft
- Electrical requirements as explained in chapter 7.5
- For a fully outdoor escalator, a pump or drainage provided by the customer is necessary at the bottom part of the escalator to evacuate water.

7.1 The 6 Site Absolutes

KONE's 6 Site Absolutes are minimum requirements or conditions which must be met before the escalator or autowalk can be delivered to the site and installed. Adhering to the 6 Site Absolutes will ensure smooth cooperation between all parties involved in the project and will help to prevent unnecessary delays or additional costs.

The Site Absolutes must be agreed upon with the building contractor prior to order and they must be available at the date of installation. Regulations in different countries may vary, but the Site Absolutes are not negotiable. Note also that the Site Absolutes are used for planning; the job-specific conditions are defined in the contract.

Prior to delivery and truss installation:

1. Wellway/pit construction

All of the following items must comply with approved KONE layout drawings:

- Escalator support angles
- Face-to-face dimensions
- Pit dimensions
- Pocket depth
- Rise
- Mounting locations.

2. Safety requirements

Approved safety barricades must be installed around all wellway/pit openings.

3. Route of entry to the site

The agreed route of entry to the site must be available when required. The unloading area must be defined and available. Space depends on the equipment (crane, forklift, etc.) required to remove the escalator or autowalk from the truck and hoist it into final position. All installation routes must be prepared as/if required to accommodate the weight of the escalator or autowalk.

4. Provision for equipment protection

Arrangements must be made to protect the equipment from damage by other trades during the entire project, as well as from weather if the unit is installed in a building before the roof is completed.

Prior to final assembly:

5. Site and storage clean-up

The working and storage areas must be clean, dry and protected from the weather.

6. 3-phase power

Permanent final 3-phase power must be available for assembly, commissioning and testing.

7.2 Mounting locations

The escalator or autowalk is supported at each end by mounting angles which sit on support beams within the building structure. These are not provided by KONE. When designing and constructing the building structure, you must ensure that the building is able to accommodate the loads imposed by the escalator, i.e. the dead weight of the escalator and the live passenger load. You can calculate these loads using the KONE Escalator Design Tool you can find from www.kone.com and [Planning Guide InfoPack™](#).

In installations where the escalator spans an expansion joint in the building structure, mountings can be provided to accommodate up to +/-20 mm of expansion/contraction. These consist of a fixed mounting at the upper end (or in special cases at the lower end) to retain the escalator in position and a sliding mounting at the lower end to accommodate the movement of the building. The mounting locations at each end of the escalator are provided with isolation (anti-vibration) pads which dampen vibration and prevent structure-borne noise being transmitted to the building structure.

Steel shims and/or jacking bolts between the isolation pads and the mounting location (support angle) are used to adjust the level of the escalator during installation to ensure the access covers fit flush with the finished floor level of the building. Between the floor finish and the escalator, a nominal 15 mm gap must be left. This gap should be filled with a flexible filler such as silicon, so that the vibration isolation between the escalator and the building structure is not compromised.

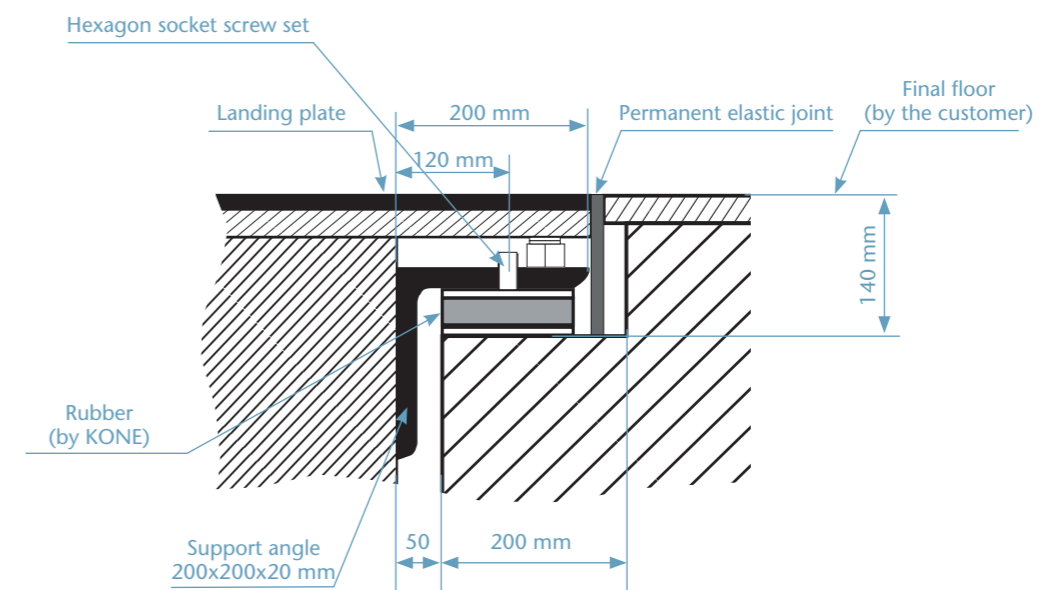

Figure 7.1 Escalator mounting angle

7.3 Intermediate truss support

When the length of the escalator/inclined autowalk would result in the truss exceeding the maximum permitted deflection of 1/750 of the distance between supports, an intermediate truss support should be provided.

The support should sit on a structural support (not provided by KONE). For ease of installation, you are advised to omit the structural support until the escalator or inclined autowalk is ready to be lowered into its finally installed position. For details of the maximum permitted truss spans and possible locations for intermediate truss supports please contact your local KONE sales engineer, or use your KONE Escalator Design Tool.

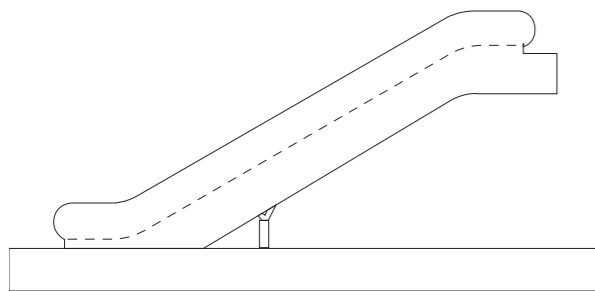

Figure 7.2 Intermediate truss support

NOTE: It is possible to make the most of the space under the truss with an intermediate support:

- Some transit providers prefer not to have an intermediate support for the escalator, but do not plan the use of the space below the escalator
- Often in these cases a cleaning closet or storage facility is located under the unit
- This closet/storage could house an intermediate support and with that lower the cost of the solution.

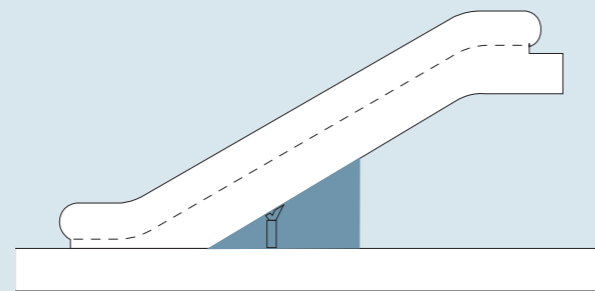

Figure 7.3 Intermediate truss support hidden in the storage space

7.4 Measurements prior to installation

You should ensure that the following measurements are taken prior to installation of the escalator. The dimensions should be checked against the contract-specific KONE layout (arrangement) drawings before installation is started:

- 1 Pit depth
- 2 Pocket depth in reference to finished floor
- 3 Vertical rise
- 4 Face-to-face of supports
- 5 Pocket width
- 6 Pit length
- 7 Rough opening width
- 8 Face-to-face measurement
- 9 Intermediate support height
- 10 Intermediate support width
- 11 Intermediate support position from lower end
- 12 Intermediate support position from upper end
- 13 Intermediate support length
- 14 15 Pocket opening width

Rough openings top and bottom in line with each other
Power supply location

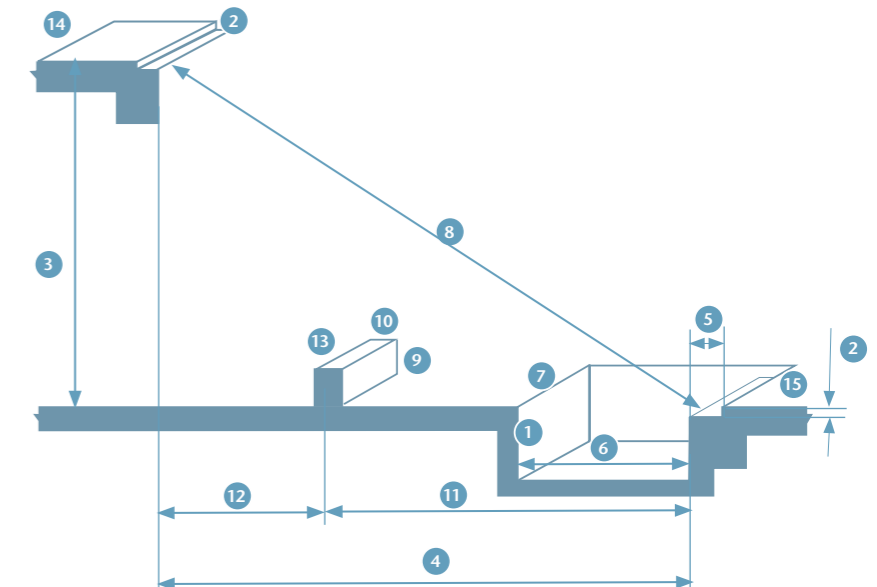

Figure 7.4 Building structural dimensions to be verified prior to installation

7.5 Electrical requirements

In general, the electrical supply is connected at the upper side of the escalator or autowalk. The layout drawings will specify the number and minimum cross-section of the connecting cables.

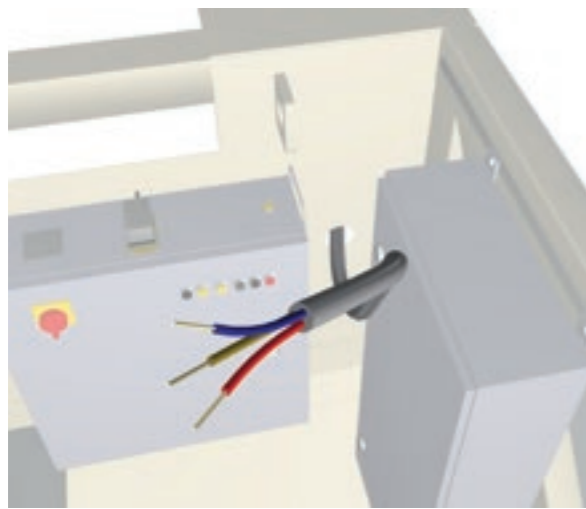

Figure 7.5 Electrical requirements are specified in KONE's layout drawings

NOTE: All electrical supply connections are your responsibility following KONE's instructions on the layout drawings, and should be implemented by an authorized electrician.

7.6 Sprinkler system

Sprinkler pipe work within the escalator truss and inclined autowalk is available with our units. Only the pipe work is supplied by KONE and this incorporates outlets for the sprinkler heads both internally within the upper and lower machine compartments, and externally in the soffit. The sprinkler heads and connection to the water supply are not provided by KONE.

As the position and spacing of the sprinkler head outlets depend on the local building regulations and code requirements, you are advised to contact your local KONE sales organization for the specific positions.



Figure 7.6 A sprinkler system can be integrated at the bottom of the escalator

7.7 Preparing to unload the escalator

Before the escalator or autowalk can be unloaded, the KONE supervisor will check and take care of the following:

- Make an inventory of the incoming equipment
- Plan the unloading before moving any equipment
- Position the truck for safe and efficient unloading
- Use a strong enough vehicle to transport the materials from the delivery truck to the designated area
- Store the material close to the wellway, if possible, and in the order they will be needed for installation.

7.8 Unloading the escalator

The preferred method for unloading the escalator is to hoist it using a mobile crane directly from the truck into the wellway or to its final position. Alternatively, the escalator can be unloaded from a flat bed truck, rail car or other transporter using forklift trucks or other suitable lifting equipment.



Figure 7.7 Unloading an escalator using forklift trucks

A photograph of a worker wearing safety glasses and a blue lanyard with an ID badge, looking out from a large glass window of an airport terminal. The background shows an airport tarmac with various ground support equipment and aircraft.

SUMMARY

The site has been prepared in advance, the Site Absolutes have been met, the mounting locations and truss supports are in place, the electrician has performed his work and the escalator or autowalk has been delivered and unloaded. Now it's time to install your unit.

*Schiphol Airport
Amsterdam, The Netherlands
48 KONE escalators
51 KONE autowalks*



8. INSTALLING THE ESCALATOR OR AUTOWALK

Escalators and autowalks are physically large, expensive pieces of equipment. It is therefore vital that you thoroughly discuss with KONE the means of installing them into the building and their protection following installation. The actual method of installing an escalator varies from site to site. However, it does tend to be a variation of one of these three basic methods:

- Installation in one complete section by mobile/site tower crane directly into position
- Installation through the building in one complete section
- Installation through the building in two or more sections due to site access restrictions and high rise.

These are explained in detail in this chapter, along with other factors to take into consideration during installation, and how best to protect your escalator or autowalk after it has been installed.

For all installation it is important to plan ahead, to define the most efficient and safe installation method and to minimize the disruption of other trades on site.

8.1 Installation in one complete section

Installation in one complete section is the preferred method of installation as in most cases it is the least expensive if the crane and protection are provided by the contractor. Our KONE installation team provides support to define the most efficient and safe installation method.

Advantages and disadvantages

- + Installation is very quick and simple
- + Lifting frames are not required
- + Under-floor propping or load spreading is not required
- + As escalator is installed in one complete section; site assembly and testing period is minimized
- Only practical in new buildings before roof is constructed
- Escalator is exposed to weather conditions until roof is completed
- Increased risk of damage due to escalator being installed earlier in construction program; has to be constructed directly over escalators
- A large expensive crane may be required to hoist escalator from truck to finally installed position



Figure 8.1 Installation in one complete section by a crane is probably the quickest and simplest method

8.2 Installation through the building in one complete section

Installation through the building in one complete section is most commonly used when installing escalators into an existing building where removing the roof above the escalator wellway is not feasible. A wide route of entry is required to maneuver the escalator through the building and into position. This can be difficult to provide in an existing building. If the route of entry involves maneuvering around corners, this may not be possible with the escalator in one complete section due to its length.

Advantages and disadvantages

- + Escalator is installed into a weatherproof building
- + Only a small mobile crane is required for off-loading the escalator from the truck
- + As the escalator is installed in one complete section, the site assembly and testing period is minimized
- + Balustrade can be removed, if necessary, to minimize headroom required along route of entry
- More complicated site management
- Lifting frames are required
- Floor along route of entry may require under-floor propping or load spreading to withstand the weight of the escalator



Figure 8.2 Installation in one section using A-frames

8.3 Installation through the building in two or more sections due to site access restrictions

This method of installation is commonly used when installing escalators into an existing building where removing the roof above the escalator wellway is not feasible. The main reason for installing in two or more sections is to reduce the length of the escalator (see figure 8.3) so that it can be maneuvered along a route of entry with restricted access (such as caused by columns, having to maneuver around corners etc.), or to reduce the floor loads.

- + Escalator is installed into a weatherproof building
- + Only a small mobile crane is required for offloading escalator sections from the truck
- + Smaller sections allow installation of escalators into buildings with restricted access along the route of entry
- + Smaller sections reduce floor loads along the route of entry
- + Balustrade can be removed, if necessary, to minimize headroom required along the route of entry
- More complicated site management
- Increased manufacturing costs
- Increased installation time and cost
- Increased site assembly time and cost
- Lifting frames are required
- Floor along the route of entry may require under floor propping or load spreading to withstand the weight of escalator

8.4 Site access headroom requirements

When installing an escalator through a building, it is essential that sufficient headroom is available along the route of entry. If headroom is restricted, the balustrades can be partially or fully removed.

For example, a 4000 mm vertical rise (30 degree inclination) escalator requires approximately 2900 mm clear headroom (including transportation wheels) along the route of entry with balustrades assembled, but only 2150 mm clear headroom with balustrades removed. Please note that all measurements depend on the number of horizontal flat steps.

However, removing the balustrades increases the cost of the escalator and increases the period required on site for assembly and testing. It may prove more economical for the building contractor to remove a door frame etc. to achieve the required headroom with balustrades assembled. In the USA, all escalators are installed with balustrades not assembled at factory. We recommend that you contact your local KONE sales organization for precise transport dimension details for each escalator model. This will enable you to determine the minimum access headroom required for installation with balustrades assembled and also with balustrades removed.



Figure 8.3 Installation in sections is useful when the roof of the building can not be removed

8.5 Lifting points and lifting frames

Lifting points

When an escalator is being installed in a conventional manner (i.e. not being hoisted directly onto its mountings by a crane), lifting points above the upper and lower mountings are required. Chain hoists are suspended from these lifting points and then attached to the lifting eyes on the escalator truss to lift the escalator into position. For an escalator being installed in two sections, additional lifting points are required at the truss joint to allow the two sections to be joined together. The lifting points can either be taken from the building structure or lifting frames can be used.

Although building contractors frequently provide lifting points from the building structure, these are rarely suitable for our chain hoists and may involve major alterations to the building structure. The advantages and disadvantages of installation using lifting points in the building structure are:

- + Lifting frames are not required
- Suitable lifting points may not be readily available; major alterations to the building structure may be required to provide them.

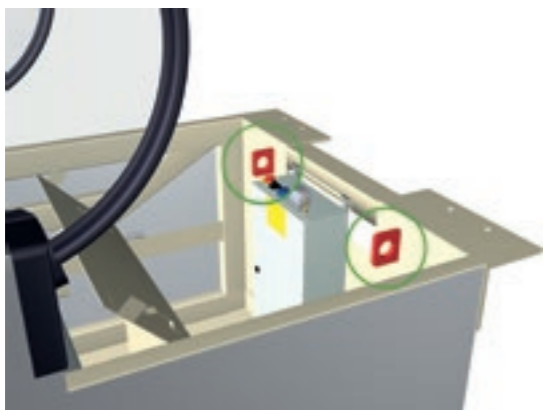

Figure 8.4 Lifting points in the escalator truss

Lifting frames

Therefore, to simplify the installation procedure it is preferable for lifting frames to be provided by KONE or the KONE installation team. The advantages and disadvantages of installation using lifting frames are:

- + The correct tool, specifically designed for the installation of escalators, is used to lift the escalators into position
- + The installation procedure is performed quickly, safely and efficiently
- + Hassle-free process for the builder; fewer design and site management interfaces
- + Lower costs for the builder
- Lifting frames may not be available locally and would have to be acquired or hired from the transport services supplier
- Floor covering or under-floor propping may be required to withstand loads imposed by lifting frames during installation
- A-frames require longer installation time and higher cost

Please note that lifting points provided by the builder are always the least expensive method for a conventional installation. Just two 100 mm holes above the last mounting (top and bottom) are required, if the floor capacity can handle the load.



Figure 8.5 Installation using a lifting frame

8.6 Protection of escalators and autowalks following installation

Immediately following the installation, it is vital that the escalator or autowalk is suitably protected to prevent it being damaged by water, dust, debris and falling objects etc. If the unit is installed in a building prior to the roof being completed, it will need to be protected against the elements. As an absolute minimum, the complete escalator or autowalk should be wrapped in heavy gauge polyethylene film to protect it from dust and water. As the units are delivered shrink-wrapped in polyethylene film, this should be left in position, where possible, and only removed where necessary to fit transportation wheels or gain access to the lifting eyes. Upon completion of the installation, the polyethylene film can then be repaired with adhesive tape.

Examples of protection that could be used in addition to polyethylene are as follows. The type of protection should be selected to suit the anticipated site conditions on each project:

- Plywood protection to the newel ends at each landing to prevent access onto the step band and balustrades.
- Plywood protection along the full length of the escalator down to outer decking level to prevent damage to the vulnerable balustrades and step band by falling debris and objects.
- Encasing the whole escalator in plywood protection to prevent damage to the vulnerable balustrades, step band and also the truss cladding by falling debris and objects.

On many projects the escalator or autowalk is installed on site for weeks or months before assembly, testing and handover to the customer. During this period, KONE may not have representatives on site full-time. Therefore, as the building contractor will have full-time site representation during this period, it is preferable that they provide the protection and take responsibility for maintaining it until the KONE engineers commence the assembly and testing work.

SUMMARY

After your escalator or autowalk has been successfully installed it will provide safe, efficient service over its long lifetime.



9. ESCALATOR AND AUTOWALK DELIVERY PROCESS

Input from customer's design team

What customer's design team can expect to get from KONE

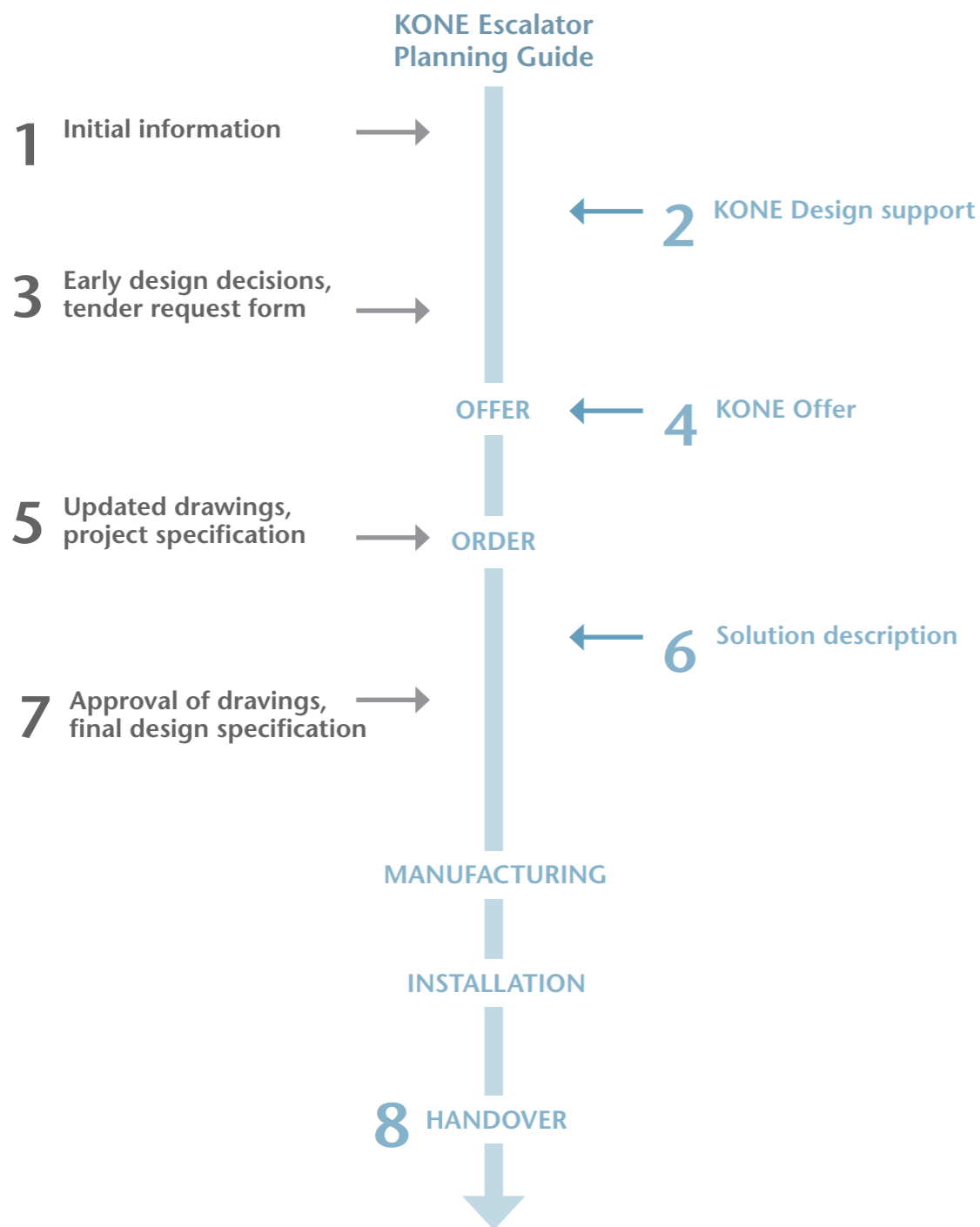

- 1** **Initial information**
Building type, floor plans, finished floor levels, number of floors, population per floor, building material. Preliminary time schedule. Possible escalator consultant's specification including ride comfort requirements.
- 2** **KONE Design support**
Initial traffic calculations, number of escalators or other alternatives, size requirements, shaft and pit dimensions. Construction time use, safety options and logistic considerations.
- 3** **Early design decisions**
Step width, inclination and load related design. Heavy load materials, electrical items. Finishing decisions, standard model or customized lighting solutions, cladding options. Building management interaction: access control, monitoring, special traffic requirements in building etc. Tender request form with project specification.
- 4** **KONE Offer**
Including drawings, electrical information and reviewed project specification.

- 5** **Updated drawings, project specification**
Latest architectural and structural drawings, with clearly marked changes. Final project specification for order. Updated time schedule.
- 6** **Solution description**
Including working drawings, details of finishings and options.
- 7** **Approval of drawings, final design specification**
Changes are to be marked clearly
- 8** **Handover**
Following inspections by KONE, customer and authorities.

10. APPENDIX EN 115-1

10.1 What is changing with EN 115-1

KONE escalators are safe and the new EN 115-1 code only enhances this safety. The changes to the EN 115-1 code are in three main areas:

- Capacity
- Equipment
- Site conditions.

10.2 Capacity

For the transport capacity the following values are defined which are different to the former version.

Step/ pallet width	Nominal Speed		
	0.5 m/s	0.65 m/s	0.75 m/s
600 mm	3,600 persons/h	4,400 persons/h	4,900 persons/h
800 mm	4,800 persons/h	5,900 persons/h	6,600 persons/h
1000 mm	6,000 persons/h	7,300 persons/h	8,200 persons/h

NOTE: Use of shopping trolleys and baggage carts (refer to Annex I, EN 115-1) will reduce the capacity by approx. 80%.

NOTE: For autowalks with a pallet width in excess of 1000 mm the capacity is not increased as users need to hold the handrail; the additional width is mainly to enable the use of shopping trolleys and baggage carts.

10.3 Equipment

The main difference in the equipment is that safety and monitoring features which were previously optional are now mandatory with every escalator or new parameters to be regarded.

These include:

- Safety switch in case of a removable hand-winding device (if the hand-winding device is removable an electric safety device shall be actuated when or before the hand-winding device is put on the machine)
- Access cover safety contacts

- Handrail speed monitoring
- Missing step monitor
- Brake lift monitor
- Anti-climb devices (building interfaces)
- Stop switches for emergency situations

The actual changes in the EN 115-1 code include a number of items. The table on the next page describes all the features, including previously optional items now delivered as standard and other general changes. Specific data, test reports and certificates are to be held by the manufacturer.

The following documentation has to be held by the manufacturer considering the new or changed test conditions:

- Stress analysis according to EN 1993-1-1 of the truss or equivalent certificate by a stress analyst
- Proof by calculation of sufficient breakage resistance of the parts directly driving the steps, pallets or the belt, e.g. step chains, racks
- Proof by calculation that the link between the operational brake and pallet or belt drive has a safety factor of at least 5 (see 5.4.1.3 EN 115-1)
- Calculation of the stopping distances for loaded escalators and autowalks (see 5.4.2.1.3.4, EN 115-1) together with adjustment data
- Proof testing of steps or pallets
- Proof of the breaking strength of the belt
- Proof of sliding coefficients for skirting
- Proof of anti-slip properties of tread surfaces (steps, pallets, floor and comb plates without combs)
- Proof of stopping distances and deceleration values
- Proof of electromagnetic compatibility
- Provide a recommendation to not use escalators as regular staircases or emergency exits as escalators are machines – even when they are out of operation – and cannot be considered as a fixed staircase.

10.4 Site conditions

The customer together with the KONE sales representative have to make sure of the following site conditions:

- Building interface requirements need to be met with necessary clearances and barriers where required. Especially where it is possible for people to come into contact with the outer edge of a handrail at a landing and can be drawn into hazardous situation, such as toppling over a balustrade, appropriate preventive measures need to be taken. For more details, refer to Annex A in the EN 115-1 and for further explanation please see chapters 6.2 and 6.5 of this Planning Guide.
- Access restriction devices are to be installed on the wall where escalators or inclined autowalks are located adjacent to walls. For more details, refer to 5.5.2.2 in EN 115-1 (item 2, Figure 4), see chapters 6.3 and 6.4 in this Planning Guide.
- Customers should take into account the friction properties of neighboring floors. These should differ only by one class in their assessment group compared to those at the landings of escalators and autowalks. For more details, refer to Annex J in EN 115-1.

10.5 Use of trolleys and shopping carts

The new EN 115-1 no longer allows trolleys and shopping carts to be used on escalators. In addition, the following new considerations are included.

Pallet width requirements for both inclined and horizontal autowalks:

Please keep in mind that if it is planned to use shopping trolleys or baggage carts on autowalks, EN 115-1 requires that the width of the shopping trolley or baggage cart and its contents should be at least 400 mm less than the nominal pallet width. Passengers should be able to leave the autowalk, even if shopping trolleys or baggage carts are on the autowalk. Since the width of most modern shopping trolleys is more than 400 mm, autowalks with a pallet width of 800 mm will in most cases be too narrow.

Therefore whenever possible we recommend the installation of autowalks with a pallet width of 1000 mm in the EN 115 area.

More information on these requirements can be found from EN 115-1 Annex I.

Table 10.1 Following features are delivered as standard, if equipment is ordered according to EN 115-1.

Item	Feature	According to EN 115:1995 +A1:1998+A2:2004	According to EN 115-1
1	Monitoring/detection device opened for inspection covers and floor plates according to 5.2.4, EN 115-1.	Not requested	Normative
2	Anti-climbing device, access restriction device, anti-slide device and vertical deflector according to 5.5.2.2, EN 115-1.	Not requested	Normative
3	Handrail speed monitoring according to 5.6.1, EN 115-1.	Not requested	Normative
4	Missing step detector according to 5.3.6, EN 115-1.	Not requested	Normative
5	Brake lift monitoring according to 5.4.2.1.1.1, EN 115-1.	Not requested ¹	Normative
6	Emergency lighting for safe evacuation of machinery spaces	Not requested	Normative
7	Kinetic friction coefficient of skirting for leather (wet and dry), PVC (dry) and rubber (dry).	No specific value	< 0.45
8	Design of Safety signs.	According to section 15	According to Annex G
9	Maximum truss deflection between supports for public service escalators.	1/1000 of distance between supports	1/750 of distance between supports
10	Geometrical set up for automatic operation by photocells: a) minimum distance between photocell and comb intersection line 1300 mm b) by the entering of a user (start/stop operation) the step band shall move with at least 0.2 times the nominal speed when the person reaches the comb intersection line and then accelerate less than 0.5 m/s ² .	a)	b)
11	For escalators, the radius of curvature in the upper transition from incline to horizontal shall be at least 2.60 m for nominal speeds $v > 0.65$ m/s (inclination of maximum 30 degrees).	informative	Normative
12	Additional emergency stop switches for emergency situations according to 1.2, EN 115-1, for autowalks intended to transport shopping trolleys and baggage carts.	Not requested	Normative
13	Restrictions on the use of trolleys, carts, etc. on the escalator and the measures needed to prevent misuse of the equipment.	No specific restrictions section 0.5.3 out-lines simple process	Normative Annex I Trolleys not allowed on escalators
14	Fire protection: Outer and inner decking, truss, pallets/steps, track system shall be at least class C according to EN 13501-1:2007, 11.5.	Not requested	Normative
15	Removable hand-winding device requires an electrical safety switch meeting the requirements of 5.4.1.4, EN 115-1.	Not requested	Normative

¹Delivered as standard in all KONE ECO based products before EN115-1:2008.

List of figures:

Figure 3.1	Escalator components.....	10
Figure 3.2	Horizontal autowalk components	11
Figure 3.3	Inclined autowalk components	11
Figure 4.1	Typical people flow in a multi-level shopping center, showing three major peaks	19
Figure 4.2	Typical people flow in a 24h metro station with two major peaks	21
Figure 4.3	The outdoor escalator should be covered by a roof to improve passenger safety and convenience.	29
Figure 5.1	Step chain with outside rollers	41
Figure 5.2	Step chain with inside rollers	41
Figure 5.3	LED skirt spotlighting.....	45
Figure 5.4	Escalator step widths.....	46
Figure 5.5	Horizontal autowalk pallet widths	47
Figure 5.6	Inclined autowalk pallet widths	47
Figure 5.7	The nominal speeds for escalators and autowalks	48
Figure 5.8	The relationship between inclination angle and overall vertical/horizontal dimensions of escalators.	50
Figure 5.9	The relationship between inclination angle and overall vertical/horizontal dimensions of inclined autowalks.....	51
Figure 5.10	Horizontal steps/pallets enable a passenger to step safely on and off the escalator.	52
Figure 5.11	Vertical rise and speed of an escalator with two horizontal steps"	52
Figure 5.12	The number of horizontal pallets required for inclined autowalks varies with the speed and inclination (one horizontal pallet on the top, two horizontal pallets on the bottom picture)	53
Figure 5.13	Selecting the correct operational mode is essential for energy reduction.....	56
Figure 5.14	Passenger detection by radar or a photocell.....	57
Figure 5.15	A glass balustrade is an attractive option for shops and airports.....	58
Figure 5.16	A solid inclined balustrade is more suitable for infrastructure escalators	58
Figure 5.17	Standard arrangement without extended balustrade requires 90° static railings to be installed for safety reasons.....	59
Figure 5.18	Different extended balustrade lengths	59
Figure 5.19	An extended balustrade allows railings to neatly butt against the escalator balustrade.....	59
Figure 5.20	Balustrade height alternatives	60
Figure 6.1	Passenger circulation area for single escalators a) and b)	64
Figure 6.2	Passenger circulation area for parallel escalators	64
Figure 6.3	Minimum free area around escalators and autowalks	65
Figure 6.4	Minimum headroom clearances.....	65
Figure 6.5	Head guard	66
Figure 6.6	Anti-slide cones	66
Figure 6.7	Anti-climb device.....	67
Figure 6.8	Deck guard.....	67
Figure 6.9	Head guards for parallel escalator	68
Figure 6.10	Head guards for single escalator.....	68
Figure 6.11	Head guards for scissored escalators.....	68
Figure 6.12	Head guards for criss-cross escalators.....	68
Figure 6.13	Clearances for customer railings according to EN 115-1	69
Figure 7.1	Escalator mounting angle.....	75
Figure 7.2	Intermediate truss support.....	76
Figure 7.3	Intermediate truss support hidden in the storage space	76
Figure 7.4	Building structural dimensions to be verified prior to installation.....	77
Figure 7.5	Electrical requirements are specified in KONE's layout drawings	78
Figure 7.6	A sprinkler system can be integrated at the bottom of the escalator.....	78
Figure 7.7	Unloading an escalator using forklift trucks	79
Figure 8.1	Installation in one complete section by a crane is probably the quickest and simplest method	84
Figure 8.2	Installation in one section using A-frames.....	85
Figure 8.3	Installation in sections is useful when the roof of the building can not be removed	87
Figure 8.4	Lifting points in the escalator truss	88
Figure 8.5	Installation using a lifting frame.....	88

List of tables:

Table 3.1	The main transportation characteristics of escalators, autowalks and elevators	12
Table 4.1	Traffic capacity calculations according to EN 115-1	16
Table 4.2	Typical configurations for commercial units	23
Table 4.3	Typical configurations for infrastructure units	23
Table 4.4	Recommended specifications for a semi-outdoor escalator.....	31
Table 4.5	Recommended specifications for a fully outdoor escalators.....	31
Table 5.1	Summary of the speeds available with KONE escalators and autowalks.....	49
Table 5.2	The most common vertical rises used in different buildings	54
Table 5.3	Recommended transition radii for escalators.....	55
Table 10.1	Following features are delivered as standard, if equipment is ordered according to EN 115-1.....	96

